

Exploiting demand-side flexibility: State-of-the-art, open issues and social perspective

F. D'Ettoire^{a,*}, M. Banaei^a, R. Ebrahimi^a, S. Ali Pourmousavi^b, E.M.V. Blomgren^a, J. Kowalski^c, Z. Bohdanowicz^c, B. Łopaciuk-Goncaryk^{c,d}, C. Biele^c, H. Madsen^a

^a Technical University of Denmark, Department of Applied Mathematics and Computer Science, Denmark

^b The University of Adelaide, School of Electrical and Electronic Engineering, Australia

^c National Information Processing Institute, al. Niepodległości 188 b, 00-608 Warsaw, Poland

^d University of Warsaw, Faculty of Economic Sciences, Poland

ARTICLE INFO

Keywords:

Energy flexibility
Demand response
Measurement and verification
Baseline methodologies
Social perspective
Smart grids

ABSTRACT

Demand-side flexibility will play a key role in reaching high levels of renewable generation and making the transition to a more sustainable energy system. Indeed, end users can actively contribute to grid balancing and management, if equipped with energy management systems and communication infrastructure. Demand response programmes encompass a broad range of load management measures, such as direct or indirect load control, aimed at adapting end users' consumption to grid needs. However, the flexibility potential of the demand side has not yet been fully exploited. The demand response programmes have not been fully realised in practice and different barriers are yet to be addressed properly. Among others, these include a fragmented regulatory framework, the lack of market products suitable for small end users, and the lack of common measurement and quantification methodologies. The present article provides an overview on the state-of-the-art of demand response programmes and their current implementation. Measurement and verification methodologies are also presented with a special focus on baseline estimation methodologies for quantifying the flexibility provided by the demand side through demand response programmes. Alongside technical and regulatory aspects, the social perspective on demand response is investigated through a quantitative survey carried out in four different European countries: Denmark, France, Italy and Spain. Finally, open issues and research gaps are identified and analysed to provide recommendations for future research activities.

1. Introduction

Further increasing renewable energy sources (RESs) in the energy mix is widely seen as one of the most important steps towards the decarbonisation of the energy sector, while increasing competitiveness and supply security. Nevertheless, the higher the share of RESs in the grid, the higher the amount of reserves needed to ensure the continuous match between the supply and aggregate demand. Indeed, high levels of inverter-based generation, like wind and solar, reduce the spinning reserves and system inertia, thus making the system balance more challenging. Furthermore, the variable and stochastic nature of RESs leads to severe ramping events that need to be compensated by more flexible resources, e.g. synchronous machines in conventional grid [1]. However, due to the increasing level of cheap renewable generation, most conventional power plants must reduce or completely stop their

generation, thus creating a shortage in the availability of dispatchable generation, which nowadays represent the main source of flexibility of the power grid.

Alongside traditional resources, i.e. supply-side flexibility, other options to increase the power grid flexibility are: (i) storage (e.g. pumped hydro storage system and large-scale batteries), (ii) network upgrades (e.g. expansion of transmission and distribution grids), and (iii) demand-side flexibility (e.g. controllable/shiftable loads) and energy system integration [2,3].

Pumped hydro storage systems are the most common form of grid-connected energy storage worldwide [4]. However, they require specific geographical features (e.g. a lower and a higher elevation water reservoir), water resources and expensive infrastructure [5], which lead to high capital costs and significant lead time. Large-scale batteries are

* Corresponding author.

E-mail addresses: frade@dtu.dk (F. D'Ettoire), moban@dtu.dk (M. Banaei), raze@dtu.dk (R. Ebrahimi), a.pourm@adelaide.edu.au (S.A. Pourmousavi), emvb@dtu.dk (E.M.V. Blomgren), jkowalski@opi.org.pl (J. Kowalski), Zbigniew.Bohdanowicz@opi.org.pl (Z. Bohdanowicz), bgoncaryk@wne.uw.edu.pl (B. Łopaciuk-Goncaryk), Cezary.Biele@opi.org.pl (C. Biele), hmad@dtu.dk (H. Madsen).

<https://doi.org/10.1016/j.rser.2022.112605>

Received 28 June 2021; Received in revised form 9 May 2022; Accepted 12 May 2022

Available online 25 May 2022

1364-0321/© 2022 The Author(s). Published by Elsevier Ltd. This is an open access article under the CC BY license (<http://creativecommons.org/licenses/by/4.0/>).

List of abbreviations

| | |
|----------------|--|
| <i>ADMM</i> | Alternating Direction Multiplier Method |
| <i>AMI</i> | Advanced Metering Infrastructure |
| <i>ATT</i> | Attractiveness |
| <i>BEHVL</i> | Behavioural |
| <i>BESS</i> | Battery Energy Storage System |
| <i>BL</i> | Baseline Load |
| <i>BRP</i> | Balance Responsible Party |
| <i>BTM</i> | Behind-The-Meter |
| <i>CHP</i> | Combined Heat and Power |
| <i>CL</i> | Controllable Load |
| <i>DER</i> | Distributed Energy Resources |
| <i>DG</i> | Distributed Generation |
| <i>DLC</i> | Direct Load Control |
| <i>DP</i> | Dynamic Programming |
| <i>DR</i> | Demand Response |
| <i>DSF</i> | Demand-Side Flexibility |
| <i>DSO</i> | Distribution System Operator |
| <i>EA</i> | Evolutionary Algorithm |
| <i>EC</i> | Economic |
| <i>EES</i> | Electric Energy Storage |
| <i>EH</i> | Electric Heater |
| <i>ENV</i> | Environmental |
| <i>EV</i> | Electric Vehicle |
| <i>FC</i> | Fuel Cell |
| <i>FESS</i> | Flywheel Energy Storage System |
| <i>G2V</i> | Grid-to-Vehicle |
| <i>GA</i> | Genetic Algorithm |
| <i>GB</i> | Gas Boiler |
| <i>H2V</i> | Home-to-Vehicle |
| <i>HEMS</i> | Home Energy Management System |
| <i>HP</i> | Heat Pump |
| <i>I&C</i> | Industrial and Commercial |
| <i>ICE</i> | Internal Combustion Engine |
| <i>ICT</i> | Information and Communication Technology |
| <i>IoT</i> | Internet-of-Things |
| <i>ISO</i> | Independent System Operator |
| <i>KPI</i> | Key Performance Indicator |
| <i>LFM</i> | Local Flexibility Market |
| <i>LP</i> | Linear Programming |
| <i>M&I</i> | Maintenance and Installation |
| <i>M&V</i> | Measurement and Verification |
| <i>MILP</i> | Mixed-Integer Linear Programming |
| <i>MPC</i> | Model Predictive Control |
| <i>NLP</i> | Non Linear Programming |
| <i>NMC</i> | Nickel-Manganese-Cobalt |
| <i>NRA</i> | National Regulatory Authority |
| <i>OC</i> | Optimal Control |
| <i>P2H</i> | Power-to-Heat |
| <i>P2P</i> | Peer-to-Peer |
| <i>P&C</i> | Privacy and Control |
| <i>PCM</i> | Phase-Change Material |
| <i>PV</i> | Photovoltaic |
| <i>PVT</i> | Photovoltaic thermal |

| | |
|-------------|--------------------------------|
| <i>QP</i> | Quadratic Programming |
| <i>RBC</i> | Rule-Based Control |
| <i>RES</i> | Renewable Energy Sources |
| <i>RL</i> | Reinforcement Learning |
| <i>RO</i> | Robust Optimisation |
| <i>RTO</i> | Regional Transmission Operator |
| <i>RTP</i> | Real Time Prices |
| <i>SC</i> | Supercapacitor |
| <i>STC</i> | Solar Thermal Collector |
| <i>TECH</i> | Technical |
| <i>TES</i> | Thermal Energy Storage |
| <i>ToU</i> | Time-of-Use |
| <i>TSO</i> | Transmission System Operator |
| <i>V2G</i> | Vehicle-to-Grid |
| <i>V2H</i> | Vehicle-to-Home |
| <i>VPP</i> | Virtual Power Plant |
| <i>WM</i> | Washing Machine |

peaking generation and demand-side flexibility often represent cheaper alternatives [7]. Similarly, network upgrades are capital-intensive and characterised by long lead times (up to 10 years) [8]. Moreover, the uncertainty associated with the expected demand and RESs growth creates the so-called “option value” of using different flexibility sources as an alternative to network expansion and upgrades [9]. In this regard, Demand Response (DR) has been shown to be an effective solution to reduce peak load and defer the cost of extending or reinforcing the network infrastructure [10]. It also enables an active participation of the demand side in grid operations (e.g. to manage the variability from renewable generation), which results in improving the efficiency, reliability, and safety of the power system [11]. The potential of DR has already been recognised by the authorities around the globe, e.g. in the “Clean Energy for all Europeans” (also known as Clean Energy Package — CEP) bill by the European Union [12]. The CEP introduced amending directives on Energy Efficiency [13] and Electricity [14], and the new Electricity regulation [15] which together define a comprehensive framework for the promotion of DR. More specifically, they introduced measures aimed at promoting dynamic pricing schemes and supporting the market access of DR, defining the role of aggregators and energy communities, and incentivising the use of flexibility from DR in distribution networks to relieve congestion and improve the efficiency of the system [16]. Despite all the efforts from different stakeholders in the last decade or so, the DR programmes have not found their place in the power system operation as an indispensable tool for flexibility provision [17].

From a regulatory perspective, a fragmented situation can be noticed across EU Member States, where only a few countries updated their regulatory framework to open their electricity markets to the demand side and other Distributed Energy Resources (DER) [18].

Besides the fragmented regulatory framework, a major barrier is the lack of clear DR performance measurements. Defining transparent and reliable measurement and verification (M&V) methodologies is crucial for enabling end user participation in energy markets and to develop fair flexibility markets and DR programmes [19]. Indeed, it would be impossible without proper M&V to evaluate the load variation provided by a demand resource, verify its commitments, and settle the corresponding incentive or penalty payments. Moreover, a counterfactual (reference or baseline) is needed to evaluate the load variation, which is proven not to be a trivial task.

Last but not least, it is worth mentioning that the social acceptance and impact of the different DR measures are equally important for developing a successful business model of demand-side flexibility.

also gaining increased interest for energy and power applications [5]. However, high upfront investment cost is still a barrier to the growth of their market [6]. As a result, transmission network interconnection,

Despite the number of works on DR and its applications published over the last few years, further research is needed. Previous works mainly focused on the theoretical framework of DR with the aim of assessing the flexibility potential of the demand-side, on the one hand, and developing control automation solutions and market mechanisms, on the other hand. Kathirgamanathan et al. [20] examined research papers on utilising data-driven predictive control for demand side flexibility applications with a special focus on the nexus of model development and control integration. Gao et al. [21] summarised the decision-making strategies of profit-seeking DR aggregators and the challenges that they face when participating in electricity markets. Similarly, Lu et al. [22] presented a review on aggregators' roles in electricity markets as well as what differentiate them from other market entities and available business models. However, DR measurement and verification procedures were poorly discussed, despite their impact on wider acceptance and application of DR mechanisms in the market framework. Moreover, most of the works investigated cost-optimal control and bidding strategies by means of numerical simulations, which are not always capable to highlight issues that might arise during the real-life implementation of the proposed solutions. Parrish et al. [23] conducted a systematic review of international DR trials, programmes and surveys, aimed at identifying barriers and enablers to end-users engagement with residential DR. Nevertheless, they do not provide a quantitative description of their findings; hence an inductive categorisation of findings across studies. To contribute to a more comprehensive view on DR and its applications, this paper builds on previous works through a review of the existing research by:

1. focusing on real-life implementation of DR and its measurement and verification procedures;
2. investigating the end-users acceptance of DR through quantitative results from a social survey conducted in four different European countries: Denmark, France, Italy, and Spain.

The rest of the paper is organised as follows. Section 2 offers the definition of DR and its main classification scheme. Then, Section 3 reviews the main baseline estimation methodologies for M&V of DR. Section 4 introduces the end user perspective on DR. To that end, experimental results from a social study are presented and discussed. Section 5 outlines the main challenges and barriers that still need to be addressed to fully accomplish the implementation of DR. Finally, Section 6 summarises the main findings of the work and provides recommendations for future research directions.

2. Background

The concept of demand control for the benefit of power system operation is not a new one. Interruptible load schemes encouraging large industrial and commercial consumers to shed their load during critical peak hours in return of payments has been in place for decades. What is new with modern DR is a more active involvement of customers of all sectors (including the transportation and residential sectors) as well as the mechanisms through which the demand-side flexibility is provided. Since the need for demand flexibility is becoming a lot more dynamic, more dynamic mechanisms like dynamic pricing or market-based mechanisms are needed. Based on these two mechanisms, DR programmes can be classified as:

- Implicit DR: consumers choose to be exposed to time-varying electricity prices and/or network tariffs;
- Explicit DR: consumers choose to participate in energy markets (e.g. through an aggregator) and receive payments in return for the load variation offered and accepted on the market.

Fig. 1 summarises the DR process for both mechanisms mentioned above.

Based on the timescale (from real-time to long term) and the objective of the DR action, it is possible to identify a wide range of demand-side flexibility applications, as shown in Table 1.

Load curtailment/shedding programmes for large industrial customers have been in place for more than 50 years [24], which can be considered as one of the most mature form of DR. In these programmes, high level of electric loads together with the availability of the facilities and communication infrastructure needed to promptly adjust the power consumption, made industries more suited to provide operational reserves compared to residential and commercial customers. Since 1960s, however, the adoption of electric heating systems have enabled the residential and commercial sectors to engage in different forms of DR [25]. Static time-of-use tariffs were introduced to flatten the demand curve, by promoting the use of electric devices during off-peak hours, when power demand was generally low and affordable. In recent years, aggregators started offering to residential and commercial end users the possibility to exploit their flexibility through market-based mechanisms. However, regulatory barriers, as well as the lack of market products suitable for small end users, still challenge their implementation. Power-to-heat technologies, such as electric heating systems (e.g. heat pump), have also enabled sector coupling, which further increases the energy flexibility of the overall power system. For instance, in Denmark, centralised heat pumps in combination with district heating networks have been used to produce heat during low-tariff hours or period of abundant renewable generation [2]. Alongside these mature DR methodologies, new opportunities are arising from advances in technologies, such as electric vehicles (EVs) and hydrogen technologies, and automatic control solutions (e.g. smart charging of EVs). EVs can provide balancing services to the grid, as well as back-up energy to power up end-users' loads, by adapting their charging/discharging cycles to grid/end-users needs. Similarly, hydrogen offers an interesting power-to-fuel solution to exploit renewable power. Electrolysers, which use electricity to split water into hydrogen and oxygen, can provide demand side flexibility by adjusting hydrogen production to follow renewable generation in periods of high resource availability, hence low electricity prices. However, the amount of hydrogen nowadays produced with renewable power is very low (only 4% of hydrogen production, mainly as a by-product [2]), and infrastructure needs (e.g. availability and distribution of charging stations) and technological challenges (e.g. EV battery life and cost, charging time), still limit the sector's available flexibility. Besides supporting grid operation, DR can be used to enhance the reliability of microgrids and lowering their operating costs [26]. Similarly, smart energy communities consisting of consumers, distributed generation, and prosumers mutually connected through a smart community manager capable to control the aggregated consumption and generation can exploit DR mechanisms to reduce their operating costs, while providing balancing services to the grid [27].

2.1. Implicit DR

Under implicit DR mechanisms, end users are exposed to time-varying energy prices or network tariffs (or both) that, compared to the traditional flat tariffs, are more cost-reflective of the generation and network costs [16]. This allows for an increase in consumer awareness of the impact of their electricity usage on the overall system costs, and enables them to reduce their energy expenses by shifting their consumption toward low tariff hours.

Simple ToU tariffs represented a first attempt to achieve these goals. However, the increasing level of non-dispatchable RESs into the grid together with the high-variability of their generation calls for a more dynamic engagement of the demand side flexibility. This understanding can clearly be seen in the recast Electricity Directive [14] that entitles all final customers who have a smart meter installed to conclude a dynamic electricity price contract with a supplier.

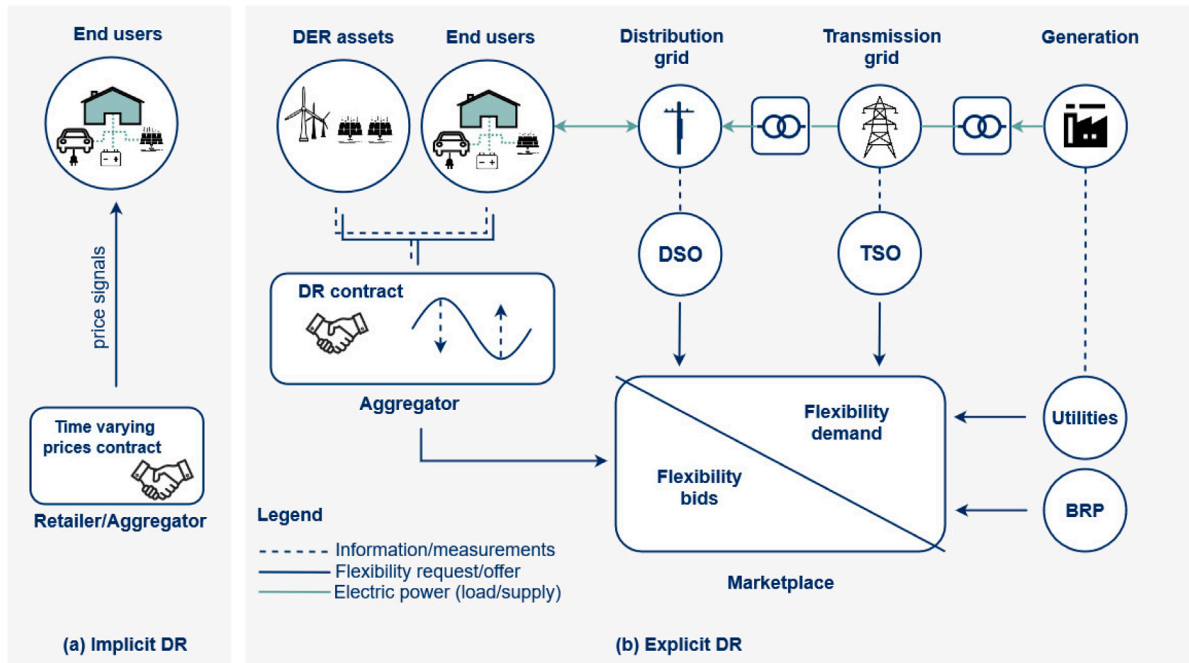

Fig. 1. Demand-response (DR) process flow: (a) implicit DR, (b) explicit DR.

Table 1
Demand-side flexibility applications classified by technological maturity and flexibility time scale.
Source: IRENA [2].

| Application | Time scale | Flexibility resource | Maturity |
|---|------------|----------------------------------|----------|
| Balancing unpredictable fast changes | Seconds | Industrial DR providing reserves | ● ● ● |
| | | Aggregators providing DSF | ● ● ○ |
| | | Smart charging EVs | ● ○ ○ |
| | | Electrolysers providing reserves | ● ○ ○ |
| Balancing forecast errors (load and generation) | Minutes | Aggregators providing DSF | ● ● ○ |
| | | Smart charging EVs | ● ○ ○ |
| Balancing variability in net load | Hours/Days | Electric water heaters | ● ● ● |
| | | District heating | ● ● ● |
| | | Aggregators providing DSF | ● ● ○ |
| | | Smart charging EVs | ● ○ ○ |
| Balancing seasonal energy availability | Months | District heating | ● ● ● |
| | | Hydrogen for seasonal DSF | ● ○ ○ |

Unlike ToU prices, dynamic pricing schemes charge rates that are not fixed in advance, and may vary in every market interval on the basis of the outcome of the electricity markets, e.g. day-ahead or intraday markets. A successful example of dynamic pricing for residential consumers is Amber Electric in Australia [28], which offers the wholesale market prices to its residential customers updated every 30 min by the Australian Energy Market Operator (AEMO). To protect customers from extreme high price spikes, Amber Electric cap the maximum price on the basis of the government’s reference price for energy. Moreover, customers can pay an insurance premium to choose their maximum prices.

Despite the adoption of dynamic prices still being relatively low, it is worth mentioning the progresses made by some European countries in that regard. In Finland, around 9% of customers have already opted for a dynamic pricing tariff based on the outcomes of the Nord Pool spot market [29]. Each day, the hourly electricity prices for the next day are published and made available to customers from the chosen retailer’s website. The day after delivery, customers can access and analyse their hourly energy consumption from their local distribution system operator’s (DSO’s) web portal or application. Similarly, 45% of Norwegian residential consumers, as well as the majority of Swedish households, have variable price contracts, i.e. a fixed tariff agreed between the consumer and the retailers plus the monthly average

Nord Pool spot price [30]. In Spain, a system called “Voluntary Price for Small Consumer” (PVPC) is available for all customers with a contracted power capacity lower than 10 kW [31]. Under this scheme, end users are exposed to the hourly electricity prices resulting from the electricity market and published by Red Eléctrica, the transmission operator of the Spanish electricity system, the day before their implementation. This way, customers can adapt their energy consumption to the real-time electricity prices. The PVPC pricing scheme only refers to the cost of producing electricity, while the component of the electricity bill covering grid operators’ expenses is fixed by the Spanish Ministry of Industry. Alongside the above mentioned countries, France, Estonia and UK also show an advanced framework in terms of the application of dynamic tariffs, while all the others EU countries still mainly offer different forms of ToU tariffs [32].

In this context, adopting advanced metering infrastructure (AMI) and increasing end users’ awareness of their energy consumption are crucial for a successful implementation of implicit DR mechanisms [33]. Indeed, to establish the amount of electricity used in each tariff block, and hence bill customers accordingly, the use of a smart meter recording consumption data at the time granularity level (e.g. hourly, half-hourly or 15 min metering) of the market is required. Moreover, customers need information and communication technology (ICT) solutions to get notice of the dynamic price profile and schedule

their consumption accordingly. In that regard, the experience gained with static ToU tariffs showed that a higher level of automation at customers' premises (e.g. home energy management systems) is needed. Indeed, people unconsciously consume energy and their behavioural intentions often differ from their behavioural actions [34]. Similarly, ICT and Internet-of-Things (IoT) solutions will be increasingly important for monitoring network dynamics and grid constraints and to consider them in the dynamic tariff design [32].

Moreover, it is worth mentioning that only the energy component of the electricity bill is subjected to dynamic variations in the dynamic pricing programmes presented above. In countries like Denmark or Germany, it accounts for approximately one-third of the final electricity bill paid by the customer [35]. Network costs (which include transmission and distribution) as well as taxes and levies cover the remaining 70% of the bill, and are usually fixed components regulated by National Regulatory Authorities (NRAs). These fixed components can dampen the price signal to customers, which does not reflect the market scarcity and actual generation costs, and limit the achievable cost saving potential. Additionally, the capital investment required to equip households with ICT and smart home energy management systems [36] (only to recover the cost over so many years) can further hamper customer willingness to opt for dynamic price contracts. The introduction of dynamic network tariffs may help to mitigate these issues as well as to link network tariffs to the correct marginal network costs [17].

2.2. Explicit DR

Unlike implicit DR, demand-side flexibility is considered a dispatchable resource in explicit DR mechanisms, which can be traded in energy or balancing markets [37,38]. This can be done either by contracting with customers the right to disconnect their loads at certain points in time and for a given period, or giving them incentives to reduce their own loads, so that customers can choose themselves how much of their load shall be reduced, and how the reduction shall be made.

According to a recent survey of the Smart Energy Demand Coalition (SEDC) on the current state of explicit DR in Europe, to enable demand-side participation in energy markets and offer new flexibility resources to both TSOs and DSOs it is still necessary to [19]:

- open all electricity markets to demand-side resources;
- clearly define roles and responsibilities among market players, especially with regard to the new figure of the aggregator and its relationship with retailers and Balance Responsible Parties (BRPs);
- identify customer-oriented market products;
- develop measurement and verification procedures and baseline methodologies to validate the service provided against the specification of the product traded into the market;
- ensure fair payments and penalties.

Explicit DR mechanisms mainly involve large-scale industrial and commercial (I&C) customers in European electricity markets [39]. However, markets products for explicit DR for small residential customers are becoming available.

In Finland, the energy company Helen Ltd [40] offers to both large and small-scale end users the possibility to exploit their flexibility to provide ancillary services in return for economic benefits. Direct load control (DLC) actions are implemented through smart control devices which are directly provided and installed by the company. Similarly, the Finnish company Fortum [41] offers to its residential customers the possibility to participate in the frequency containment reserve markets operated by Fingrid, i.e. Finnish TSO, through a DLC programme. It consists of aggregating electric water heaters of the customers enrolled in the programme in a virtual battery, and offering the resulting controllable load as reserve in the market. In return for

their flexibility, customers receive a discount on their annual energy bill and a smart-phone app for monitoring and controlling their electric water heaters in real-time [42].

Voltalis is a French independent aggregator that offers a DLC programme to residential customers. In this programme, the customers receive a free smart device, named "Bluepods", which, on the one hand, informs them about their energy consumption and, on the other hand, can directly control electric devices, like electric heaters [43]. In this way, Voltalis can offer the aggregated energy flexibility of its customers to RTE, i.e. the French TSO, for keeping the grid balanced during periods of peak demand. Upon request from RTE, Voltalis turns off the connected devices for a maximum of 30 min in order to reduce the aggregate demand, while ensuring no discomfort for the customers. However, customers can choose to opt out at any time by pushing a button on the Bluepods device. Moreover, they do not receive a direct payment for their load reduction, but can observe a reduction of their energy bill of about 10% [43].

Within the framework of the Cornwall Local Energy Market (LEM) project [44], the British company Centrica launched a three-year trial in 2018 to test the feasibility of trading aggregated flexibility of domestic customers into a local marketplace. Through the platform, participants were enabled to offer their flexible generation and demand in both traditional and new markets (i.e. a local flexibility market — LFM). 100 households were recruited to take part in the trial. Each house was equipped with a monitoring system (which included a mobile App to monitor the daily electricity consumption), a home battery and PV panels, all installed free of charge. Explicit DR actions were implemented through DLC. Centrica remotely controlled the batteries, while the end users were not actively engaged in using the trading platform themselves.

Similarly, Piclo launched the Piclo Flex platform in the market in 2019, an auction-based marketplace where more than 200 flexibility providers can trade over 4.5 GW of flexibility online to help network operators to cost-efficiently balance and manage the grid [45].

The two examples of flexibility platforms discussed above show that, alongside traditional electricity markets, new marketplaces such as local flexibility markets (LFMs) are gaining increasing attention. Unlike traditional markets, LFMs allow local flexibility and power (e.g. PV generation) trading at distribution level and refer to a geographically limited area such as that served by a local DSO. In this way, the DSO can exploit resources located in the distribution grid to procure flexibility in a market-based approach for non-frequency ancillary services, i.e. voltage control, congestion management, local balancing and losses reduction [46], as promoted by the amending Directive on Electricity [14].

Lastly, it is worth noticing that, as for explicit DR mechanisms, the availability of smart meters will be crucial for their successful implementation. They allow to record consumption data at a high resolution, on the one hand, and enable real-time communication, on the other hand. Without consumption data, it would be impossible to apply the measurement and verification procedures needed to verify the commitment that a demand resource made towards the market, hence settling the remuneration or penalty payments. Similarly, it would be impossible to verify if a demand-side resource, and the aggregated demand in general, meet the pre-qualification criteria required to access the electricity market.

2.3. Demand-side resources enabling DR

The term demand-side resources encompasses a broad range of loads, storage and generation assets including: controllable loads, electric vehicles (EVs), energy storage systems, distributed generation (DG) and their aggregation in virtual resources referred to as Virtual Power Plants (VPPs). The flexibility potential of these resources strictly depends on both their technical features and application field,

and thereby varies widely among sectors: industrial, commercial, and residential.

The rest of this section provides an overview of research works on the main demand-side resources and their use as flexibility service providers within the power system.

2.3.1. About commercial, industrial and residential demand

In Europe, heating and cooling applications account for almost 51% of the total final energy demand and around 43% of the latter is due to the combined demand for space and process heating [47].

An effective way of meeting these demands is to use so-called power-to-heat (P2H) technologies, namely technologies that couple the electric sector with the heating and cooling sectors and use electricity to generate heat and cooling for buildings or industrial processes [48]. In this way, the resulting electric loads can be used to implement load-management strategies aimed at exploiting the generation of renewables like wind and solar and avoid its curtailment. This will increase the overall flexibility of the power system and facilitate a higher penetration of non-dispatchable RESs. Among P2H technologies, heat pumps (HPs) are expected to play a crucial role in both building and industrial sectors [49]. Alongside heat pumps, electric heaters (EHs) are another common technology that allow use of electricity for heating purposes. Although they are less efficient compared to heat pumps, their lower capital costs make them more affordable. Combined heat and power (CHP) technologies, such as fuel cells (FCs) and internal combustion engines (ICEs), which generate heat and electricity simultaneously, are also options to unlock the flexibility of the demand-side. Such technologies are most frequently used as centralised generators in district heating networks which, together with district cooling, can significantly contribute to the power system flexibility [50].

To fully exploit the energy flexibility potential of P2H technologies, thermal energy storage (TES) is needed. Indeed, it allows decoupling of the supply from the demand, thus increasing the possibility of implementing load management strategies (e.g. load shifting), while preserving occupant comfort requirements. Sensible heat storage, like simple water tanks, is the cheapest and most commonly adopted form of thermal storage. However, such tanks are characterised by low storage density in comparison with other forms of thermal storage like latent and thermochemical heat storage technologies [51]. In this regard, it is worth underlining that district and cooling networks represents a valuable form of energy storage. Thanks to the high thermal capacity of their water content, they are capable of storing a significant amount of thermal energy.

Lastly, it is worth mentioning that alongside P2H technologies meeting the heating and cooling loads of end users, electric appliances can also contribute to providing flexibility to the grid if equipped with a proper ICT infrastructure [2].

A brief overview of research papers published on the above mentioned demand-side technologies and DR in recent years is given in Table 2.

2.3.2. Electric vehicles (EVs)

It is predicted that EVs will comprise 55% of annual vehicle sales by 2040. It means that by 2040, 33% of total cars on the road worldwide, i.e. 550 million cars, will be EVs. This growth in the EV industry facilitates decarbonisation efforts. However, it is estimated that by 2040, EVs will increase energy consumption of end users by about 11%–16%. This additional load necessitates additional grid costs for network upgrade, if it occurs during peak-load hours [80].

While large-scale utilisation of EVs confronts the power system with new challenges, it can offer new opportunities too. More EVs leads to more energy storage capacity which means more flexibility in the grid. By adapting the charging cycles of EVs to grid conditions, smart EV charging strategies can provide a wide range of services at different grid levels: (i) ancillary services at TSO level, (ii) voltage control and local congestion management at DSO level, (iii) portfolio balancing for

utilities and (iv) increase self-consumption of locally produced electricity, and provide back-up power, at end-users level. Grid-to-vehicle (G2V) and vehicle-to-grid (V2G) controlled charging and discharging can enable the provision of balancing services and energy arbitrage, while vehicle-to-home (V2H) strategies can also provide back-up power to the building and help to increase the rate of self-consumption of the locally produced electricity [81].

Table 3 presents an overview of research works published on EV participation in electricity markets in recent years.

Two aspects that need to be taken into account about flexibility from EVs are time and location. Indeed, EVs may be on the road when the system needs their storage capacity, and it is difficult to predict when this may happen. Additionally, despite the advancement of charging stations and infrastructure, EVs may not have access to bidirectional chargers for G2V and V2G services in some locations. For instance, not all the charging stations support all the different levels of charging required by the different EV models [91]. So, uncertainty around their availability at a given time and location is a barrier. Moreover, if the flexibility of batteries embedded in EVs is going to be used by local DSOs to solve geo-localised issues, such as congestion in distribution grids, then their availability in specific areas of the grid becomes even more crucial.

2.3.3. Battery energy storage systems (BESSs)

Battery storage is envisaged to be the main source of energy balancing in the future power grid [92]. Alongside utility-scale batteries, small-scale behind-the-meter (BTM) batteries have received increased attention over the last several years as a valuable storage option to provide energy system flexibility. Their fast charging and discharging capability make them very attractive for providing those services requiring a very short activation time, like primary reserve for frequency control. In Australia, Virtual Power Plants (VPP) of aggregated BTM battery energy storage systems are used, alongside centralised power plants, for network-balancing services [93]. Similar opportunities are opening up in Europe, where BTM storage is overtaking the deployment of grid-scale applications, led by Germany with over 50000 new installations solely in 2019 [94].

In 2020, Sonnen (a German battery manufacturer and solution provider) launched a VPP in northeast Germany to support the operation of the local DSO and to avoid curtailments of excess wind energy [95]. The VPP is made of interconnected home batteries primarily used in households to store local PV generation. Since 2018, Sonnen has also been providing reserve capacity for frequency regulation from BTM energy storage. In co-operation with Next Kraftwerke, Sonnen is evaluating new opportunities and revenue streams for BTM storage, like the inclusion of further reserve products such as automatic and manual Frequency Restoration Reserves (aFRR and mFRR) [96].

Alongside reserve capacity, BTM batteries can provide back-up power, contribute to voltage regulation and enable peak-shaving and energy arbitrage. For instance, end users exposed to dynamic tariffs can exploit BTM storage to implement load-shifting strategies aimed at reducing their energy expenses. Similarly, they can use BTM batteries to maximise self-consumption of on-site PV generation [97]. This will be, in particular, relevant to the phaseout of subsidy mechanisms rewarding the export of self-generated electricity to the grid. In Japan, the phaseout of such feed-in schemes represented the primary factor driving the BTM storage market in 2019 [94]. Net billing schemes can also be adopted to further valorise high levels of self-consumption [98].

According to EuPD Research, a market and economic research institute, the main factors driving the market growth of BTM batteries are: (i) new installation of integrated PV-battery systems; (ii) increase in electricity prices and (iii) considerable reduction in battery costs [99].

Table 4 provides an overview of recent works investigating the use of BTM storage for providing flexibility services at both end user and grid levels.

Table 2
Peer-reviewed papers published on demand-side technologies and DR in recent years.

| Reference | Technologies | DR type | Agg. | Real impl. | Sim. | Cont. type | Opt. method | Opt. obj. |
|---------------------------------|---------------------|-------------|------|------------|--------------------------------|-------------|-------------|--|
| Majidi et al. [52] | CHP, HP TES, GB | ToU | - | - | GAMS | RO | MILP | min costs |
| Nguyen et al. [53] | FC-CHP | P2P trading | - | - | - | - | ADMM | min costs |
| Nojavan et al. [54] | FC, PV, EES, TES | ToU | - | - | GAMS | OC | MILP | min costs, min CO ₂ |
| Majidi et al. [55] | FC, PV, EES, TES | ToU | - | - | GAMS | OC | MILP | min costs |
| Dengiz et al. [56] | HP, PV | RTP | • | - | GAMS, Java | MPC, RBC | MILP | min costs, max self-cons |
| Clauß et al. [57] | HP, STC, TES | RTP | - | - | IDA ICE | PRBC | Heur. | min costs, min CO ₂ |
| Mugnini et al. [58] | HP | DLC | - | • | MATLAB | OC | LP | min energy |
| Bee et al. [59] | HP, PV, TES | ToU | - | - | TRNSYS | RBC | Heur. | max self-cons |
| Patteeuw et al. [60] | HP, EH TES | DLC, ToU | • | - | MATLAB GAMS | MCP | MILP | min costs |
| Finck et al. [61] | HP, PVT, TES | RTP | - | • | - | MCP | DP | min costs |
| Uytterhoeven et al. [62] | HP, GB | ToU, RTP | - | - | - | MPC | LP | min costs, min energy |
| De Coninck et al. [63] | HP, GB TES | DLC | - | • | Jmodelica, Casadi | MPC | NLP | min costs, discomfort |
| Baeten et al. [64] | HP, TES | - | • | - | Dymola | MPC | QP | min costs and env. impact |
| Péan et al. [65] | HP | RTP | - | • | TRNSYS, MATLAB, LABVIEW, | MPC | MILP | min costs, energy, and CO ₂ |
| Fitzpatrick et al. [66] | HP, GB, TES | ToU, RTP | - | - | MATLAB | MPC | MILP | min costs |
| Dong et al. [67] | HP, PCM | - | • | - | Pyhton | MPC | MILP | min costs, min energy |
| Howlader et al. [68] | PV, FC, CL | RTP | - | - | MATLAB | OC | MILP | min costs |
| Renaldi et al. [69] | HP, TES | ToU | - | - | Python | MPC | MILP | min costs |
| Fischer et al. [70] | HP, PV TES | RTP | - | - | Python | RBC, MPC | QP | min costs |
| Fischer et al. [71] | HP, HP, TES | DLC | • | - | - | RBC | - | - |
| Vivian et al. [72] | HP, TES | - | • | - | - | OC | MILP | min peak load |
| Sperber et al. [73] | HP | DLC | • | - | TRNSYS, R | RBC | - | - |
| Alimohammadisagvand et al. [74] | HP, TES | RTP | - | - | IDA ICE | RBC | - | - |
| Knudsen et al. [75] | HP | RTP | - | - | MATLAB, EnergyPlus | MPC | QP | min costs |
| Alfaverh et al. [76] | Home appliances | ToU | - | - | MATLAB | OC | RL | min costs |
| Nagpal et al. [77] | Home appliances | RTP | - | - | MATLAB | MPC | MILP | min costs, peak load |
| Hafeez et al. [78] | Home appliances | RTP | - | - | MATLAB | OC | Heur. | min costs, discomfort |
| Das et al. [79] | Home appliances | ToU | - | - | - | OC | Heur. | min costs, peak load |

Nevertheless, it is worth mentioning that despite the number of services that BTM batteries can provide, nowadays they are mainly used for single services/applications only (e.g. max self-consumption, capacity reserve, etc.). It limits the profitability of BTM storage systems, which remain idle or underused most of the time [110]. Therefore, to fully exploit BTM storage and maximise its value, BTM batteries should serve multiple applications. To this end, optimal allocation to the different services of the limited energy and power battery capacities will play a crucial role in the development of successful business cases and offer new research opportunities.

3. DR baseline methodologies approaches

Despite the number of works investigating how to develop and deploy demand-side flexibility, the lack of common terminology, standards and quantification procedure is still a matter of concern [111].

Definitions and quantification methodologies generally depend on the researchers' perspectives [112], which in turn reflect the scope for which energy flexibility is used. This can clearly be seen in the variety of key performance indicators (KPIs) developed among the different research activities attempting to provide a quantitative description of energy flexibility in recent years. An extensive overview of energy flexibility indicators was provided by Kathirgamanathan et al. [20] and Clauß et al. [113]. Table 5 provides an overview on the definitions and assessment/measurement methodologies of demand-side flexibility available in the literature.

The analysis of the research works presented in Table 5 indicates that, despite their differences, all of the proposed methods rely on the same concept of flexibility, namely the capability to modulate the electrical power fed into and/or taken from the grid over time. Besides representing a common reference point to define the concept of energy flexibility, this definition also provides the basis for a common

Table 3
An overview of papers published on EV participation in electricity markets in recent years.

| Reference | Research objective | Charg. strategy | Freq. cont. | Volt. cont. | Cong. man. | Whol. market | Self cons. | Exp. val. |
|-------------------------|--|-----------------|-------------|-------------|------------|--------------|------------|-----------|
| Izadkhash et al. [82] | New aggregate model of plug-in EVs for primary frequency control. | G2V | ○ | | | | | |
| Marinelli et al. [83] | Primary frequency control from EVs via centralised control. | G2V | ○ | | | | | ○ |
| Clairand [84] | Secondary frequency response through an EV aggregator. | V2G | | ○ | | | | ○ |
| Bessa et al. [85] | Optimal bidding strategy for EVs' aggregator in day-ahead and secondary reserve markets. | V2G | | ○ | | ○ | | |
| Gunkel et al. [86] | Impact of EV charging schemes on long-term energy-system planning. | V2G | | | | | | |
| Shafie-khah et al. [87] | Optimal strategies for participation of EVs in the day-ahead and reserve markets. | V2G | | | | ○ | | |
| Jampeethong et al. [88] | Coordinated control of EVs, wind farm and PV for frequency control of a microgrid. | V2G | ○ | | | | | |
| Cao et al. [89] | Voltage regulation in a distribution grid through V2G interaction. | V2G | | ○ | | | | |
| Abul'Waf et al. [90] | Minimise total cost and the peak load considering charging for H2V and discharging for V2H . | H2V, V2H | | | | | ○ | ○ |

Table 4
An overview of the papers published on BESSs for flexibility services.

| Reference | Year | BESS tech. | BESS capacity | Scope | Optimisation | |
|----------------------------|------|------------------|-----------------|---------------------------------|-----------------------|--------|
| | | | | | Objective | Method |
| Mejía-Giraldo et al. [100] | 2019 | - | 0.11 – 1.23 MWh | Freq. control | Sizing | LP |
| Kumar et al. [101] | 2019 | - | up to 5 MWh | Voltage and freq. control | Allocation and sizing | GA |
| Engels et al. [102] | 2019 | Li-ion NMC | 1 – 2.5 MWh | Freq. control | Sizing and control | EA |
| Almasalma et al. [103] | 2020 | - | 4.8 – 13.5 kWh | Voltage and freq. control | Control | RO |
| Beltran et al. [104] | 2020 | SC, FESS, Li-ion | 0.03 – 1111 kWh | Inertia response, freq. support | - | - |
| Schiapparelli et al. [105] | 2018 | Li-titanate | 560 kWh | Freq. control | - | - |
| Engels et al. [106] | 2020 | - | 2 MWh | Peak shaving, freq. control | Control | DP |
| D. Zhu et al. [107] | 2019 | - | 20 – 25 kWh | Freq. control | Control | Heur. |
| M. Ramirez et al. [108] | 2019 | - | up to 11 MWh | Freq. control | Placement and sizing | Heur. |
| El. Bidairi et al. [109] | 2020 | - | 50 – 300 kWh | Freq. control | Sizing | Heur. |

measurement methodology. Indeed, the flexibility can be measured as the difference between the actual (measured) consumption and the baseline consumption (estimated), which would have been used in the absence of a flexibility event, although the definition of the baseline is still a matter of concern. In that regard, it is worth noticing that in most of the works summarised in Table 5, the baseline is evaluated by simulating the end users' behaviour without DR, where DR is implemented by simply changing parameters of the simulation framework. Although these works assess the flexibility potential of the demand side, they do not provide viable measurement methodologies. To this end, estimation methodologies relying on statistical method (e.g. historical data, regression methods, control groups, etc.) are needed. The next section provides an overview of the available baseline estimation methodologies and methods from time series analysis and outlines the advantages and drawbacks of each method.

3.1. Baseline methodologies

Measuring the load variation provided by a demand resource is of paramount importance for introducing explicit DR mechanisms into a market framework, hence verifying the commitments made towards the programme operators or market aggregators, and settling the corresponding remuneration or penalty payments.

However, estimating the baseline load (BL) is not a trivial task. BL methodologies should ensure accuracy, simplicity, integrity (i.e. should

not allow customers to game the system) [126], and should take into account the specific characteristics of the flexibility product, as well as its functionality in the system [127]. In the US, the Federal Energy Regulatory Commission (FERC) recognised five types of standard baseline methodologies, which differ in regards to type of data used, time-frame of historical data, and programme objective and design [126]. These BL methodologies, proposed by the North American Energy Standards Board (NAESB), are summarised in Table 6.

Baseline Type I methods are widely used to estimate the BL of commercial and industrial customers. They encompass a wide range of methods for creating a baseline load on the basis of a customer's historical meter data and weather/calendar data. These include, among others, averaging and regression methods, which will be discussed in more details in Sections 3.1.1 and 3.1.2, respectively. Unlike Baseline Type I methods, Baseline Type II methods are generally used where aggregated meter data are available but individual site meters are not. The baseline is estimated by using statistical sampling and is then allocated to no-metered individual sites or loads. Baseline Type II has been mainly used for residential DR due to the lower use of Advance Meter Infrastructure (AMI) compared to the commercial and industrial sectors. However, thanks to the ongoing large-scale deployment of smart meters and AMI in the residential sector, the use of these methods is expected to progressively decrease. Maximum Base Load methods utilise individual meter and system data from previous years to identify a reference power level below which the customer must keep

Table 5
Flexibility definitions and measurement methodologies available in the literature.

| Reference | Flexibility definition | Assessment/ Measurement | Sim. | Real impl. |
|------------------------|---|--|------|---------------|
| Finck et al. [61] | Load-shifting from high to low-price periods. | Ratio between shifted and total load. | | ○ |
| Sun et al. [114] | Load shift in response to time-varying prices. | Load variation with respect to a reference baseline estimated through historical consumption data of non-event days (i.e. without dynamic prices). | | ○ |
| D'hulst et al. [115] | Power increase or decrease that can be realised by smart appliances without compromising comfort requirements. | Maximal amount of time a given modulation of power can be sustained within the comfort requirements. | | ○ |
| De Coninck et al. [63] | Load variation (increase or decrease) to a pre-defined electricity consumption target. | The load variation is evaluated with respect to a reference scenario without flexibility request. | ○ | |
| Six et al. [116] | Capability to shift the electric demand in time thanks to TES. | Number of hours of deferred operation. | ○ | |
| Arteconi et al. [117] | Load shift in response to dynamic prices. | Load deviation with respect to a reference baseline without DR. | ○ | |
| D'Ettorre et al. [118] | Load shift in response to incentive payments. | Load variation with respect to a reference baseline without DR. | ○ | |
| Junker et al. [119] | Flexibility Function | Changes in the energy demand profile with respect to a reference scenario without penalty signal. | ○ | ○ |
| Knudsen et al. [120] | Load shifting in response to dynamic prices and CO ₂ intensity signals by using model predictive control (MPC) | Difference between the consumption patterns resulting with and without MPC. | ○ | |
| Sharifi et al. [121] | Load reduction due to a DR event. | Load reduction with respect to a baseline without DR. | ○ | |
| Le Ray et al. [122] | Load variation in response to dynamic prices. | Comparison between the low profile of customers engaged in DR with that of customers not participating in the programme. | | ○ |
| Ziras et al. [123] | Load variation due to changes in the thermostat set point | Load reduction with respect to a baseline load without DR. | | ○ |
| Müller et al. [124] | Load reduction of thermostatically controlled loads. | Load reduction with respect to a baseline load estimated on the basis of the consumption of customers not participating in DR. | | ○ |
| Corradi et al. [125] | Dynamic load response to a penalty signal (e.g. energy price). | Changes in the energy demand profile with respect to a reference scenario without penalty signal. | ○ | ○ |

Table 6
The US baseline methodologies by resource and service types [127].

| BL evaluation method | Resource type | | | Service type | | |
|---------------------------|---------------|-----|------|--------------|----------|--------------------|
| | Residential | C&I | DERs | Energy | Capacity | Ancillary services |
| Baseline Type I | | • | | • | • | • |
| Baseline Type II | • | | | • | • | • |
| Maximum Base Load | | • | | • | • | • |
| Meter before/Meter after | | • | | • | • | • |
| Metering Generator Output | | | • | • | • | • |

its consumption level upon the call to a DR event. It is worth noticing that, unlike the Baseline Types I and II, with a Maximum Base Load method, if the customers' consumption patterns are already at or below the reference power level, they can meet their commitment towards the DR programme by doing nothing. Meter Before/Meter After is usually used for DR programmes related to ancillary services and is based on the comparison between the load metered before and after the DR event. Lastly, Metering Generator Output is used for behind-the-meter onsite generation. It evaluates the load reduction as the variation in the load covered by the generator and measured through the generator output data. It is assumed that the load taken by the generator would otherwise have been on the system.

The next sections provide an overview of the most widely used techniques for BL estimation.

3.1.1. Day and weather matching methods

Day and Weather Matching Methods belong to the category of Averaging Methods. They estimate the BL by averaging historical meter data from days preceding the DR event. Fig. 2 shows the main steps of the calculation procedure.

First, a set of Y days is selected from the days preceding the DR-event day (Fig. 2a), by excluding weekends, holidays and previous event days. These days are referred to as non-DR days. Then, a sub-set of X days is extracted from the Y non-DR days (Fig. 2b), on the basis of either energy or weather selection criteria, e.g. highest/lowest consumption days or days with the minimal/maximal outdoor temperature, respectively. Lastly, the BL consumption is estimated by averaging the hourly loads of the X profiles belonging to the sub-set (Fig. 2c). By denoting the sub-set of X days as D_X and the customer's load on day d at hour t as $l(d, t)$, the BL estimate on an event day \bar{d} at hour t reads as follows:

$$BL(\bar{d}, t) = \frac{1}{X} \sum_{d \in D_X} l(d, t) \tag{1}$$

According to the adopted selection criteria, these methods can be classified as: Y-Day simple average, HighXofY, LowXofY, and MidXofY methods. As their name suggests, simple averaging methods use the average of the customer's hourly load over the Y non-DR days preceding the DR event to predict the BL on the event day. On the other hand, HighXofY and LowXofY methods use the average of the X days with the highest and lowest, respectively, electricity consumption within the

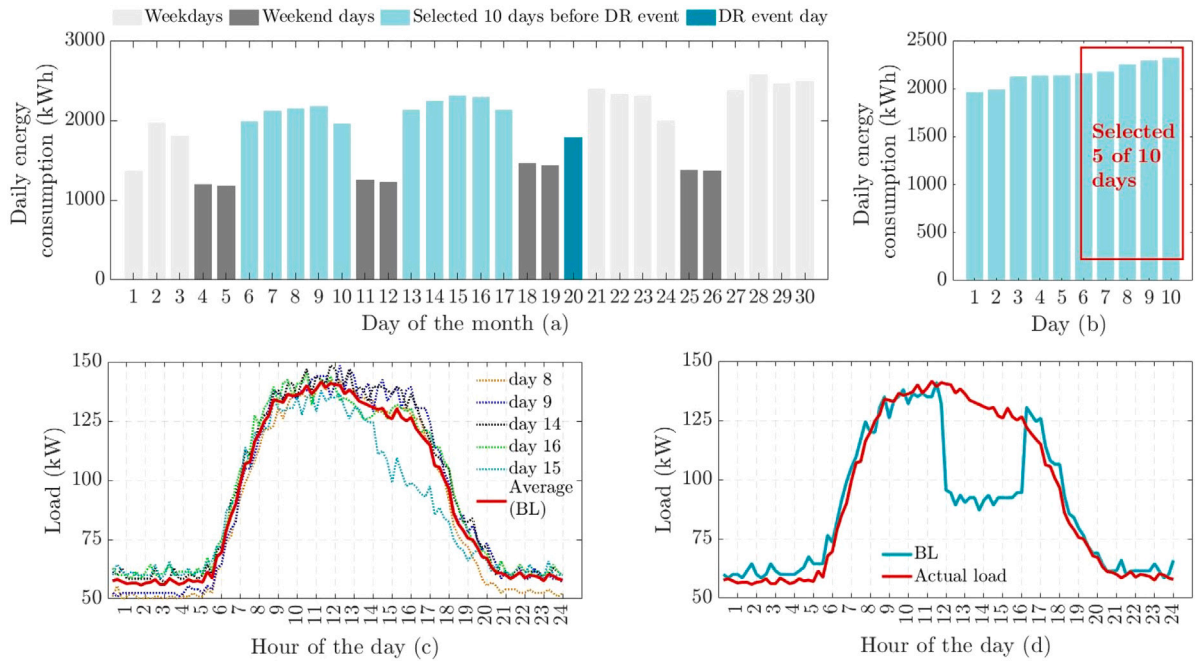

Fig. 2. Steps of Day and Weather Matching Methods calculation procedure: (a) identification of Y non-event days; (b) selection of X days with the highest consumption; (c) base load estimation (i.e. averaged consumption); (d) comparison of the base load estimate and the actual/measured load.

Table 7
Summary of the most well-established matching methods for commercial and industrial customers.

| Type | Description | References |
|----------------------|--|------------|
| Y-Day Simple Average | Average of the Y non-event-day. | [130] |
| HighXofY | Average of the X days with the highest electricity consumption within the Y days. | [126,129] |
| LowXofY | Average of the X days with the lowest electricity consumption within the Y days. | [129,131] |
| MidXofY | Average of the X middle consumption days remaining after dropping $(Y-X)/2$ days with the lowest and higher electricity consumption. | [129] |

selected Y days. These methods, also known as X of Y baseline methods, have been developed with the aim of providing the US Regional Transmission Operators (RTOs) and Independent System Operators (ISOs) with a tool for estimating the BL of commercial and industrial customers participating in DR programmes [128]. For instance, California and New York ISOs use High5of10 and High10of10, respectively, for a weekday, and High2of3 and High4of4, respectively, for a weekend DR event [129]. Lastly, MidXofY methods use the average of the X middle consumption days remaining after dropping the $(X - Y)/2$ days with the lowest and highest electricity consumption. Table 7 summarises the four methods discussed above.

These averaging methods are easy to communicate to end users, since they rely on a simple average of their previous consumption profiles, but may generate high estimation errors [132]. This is mainly due to the fact that the historical consumption data used to estimate the BL are not sensitive to the different operational conditions (e.g. climatic conditions) between the event day and the subset of X days used to estimate the BL. To increase accuracy, the baseline estimate can be adjusted by the event day data (e.g. weather, calendar or actual load data). For instance, the estimated baseline can be adjusted on the basis of the difference between the actual and the estimate load measured over a time span of 2–4 h before the start of the DR event (i.e. pre-hour adjustment). Depending on whether such difference is added or multiplied to the BL, the adjustment is called additive or multiplicative, respectively. More information about baseline adjustment can be found in [126]. Moreover, averaging methods might be easily gamed by end users (e.g. by increasing their consumption during the non-event days), and are not suited for using DR resources in the absence of non-event days. For instance, if we want end users to continuously provide balancing reserves in a grid with very high penetration of renewables,

then we will not have many non-event days. To this end, different BL estimation methods are required.

3.1.2. Regression methods

Alongside Day and Weather Matching Methods, Regression Methods have also been largely used for BL estimation. The BL is estimated through an equation fit model (Eq. (2)), which links the electricity consumption, i.e. dependent variable (y_t), to a set of n explanatory variables, e.g. historical load and weather data, which represent the independent variables $\mathbf{x}_t = (x_{1t}, \dots, x_{nt})^T$.

$$y_t = \theta^T \mathbf{x}_t + \epsilon_t \tag{2}$$

ϵ is an error term, while $\theta = (\theta_1, \dots, \theta_n)^T$ are the coefficients of the model. The latter can be inferred from historical data through different estimation techniques, like least square, lasso, and ridge regressions.

In Bode et al. [133], a least square regression is used to estimate the demand reduction of air-conditioners load, participating in a DLC programme. The regression model is used to estimate the baseline without DR and the load reduction evaluated as the difference between the baseline and the metered load during the DR event. The authors also compared the regression model with both Day and Weather Matching Methods, showing that although day matching methods can be accurate to measure reductions in commercial and industrial DR programmes, they are not well suited for measuring the demand reductions of residential customers, the latter being more weather-sensitive than industrial and commercial loads. Nevertheless, they showed that weather matching methods can work better than day matching methods thanks to their capability to take into account the impact of weather conditions. However, the accuracy of both Day and Weather

Matching Methods decreased when individual-site data were used instead of aggregated load data. On the other hand, the regression model outperformed both Day and Weather Matching Method baselines, by providing the most accurate results with both individual and aggregated data.

Similarly, Newsham et al. [134] used a least square regression to analyse the peak load reductions due to a residential DLC programme for air conditioners. However, the load reduction is explicitly calculated from the regression coefficients. The DR event-hours are used as independent variables and the estimates of their coefficients used as estimates of the programme effects.

Regression models are usually more accurate than Day and Weather Matching Methods in terms of bias and estimation error, and more difficult to game. However, regression models are more difficult to communicate to end users and sensible to changes in the consumption profile between the training and test periods, such as those due to the introduction of new technologies at customer premises (e.g. PV and batteries) [135].

3.1.3. Control group methods

Unlike matching and regression methods, control groups methods do not rely on historical data, but rather on the comparison between the aggregated load curves of responsive and non-responsive customers. These two groups are also referred to as *treatment* and *control* group, respectively. The control group is composed of customers not enrolled in DR programmes, and serves as a reference for estimating the baseline consumption of the responsive customers: its average load is used as the BL in comparison to which we can evaluate the amount of DR delivered by the treatment group, i.e. customers participating in DR programmes, during a DR event.

Control group methods are particularly suited for estimating the BL of residential customers [136], whose consumption patterns, aside from weather conditions, are strongly affected by occupancy behaviours, which are more difficult to predict. However, particular attention must be paid to the choice of the customers recruited in the two groups. Indeed, they should share similar characteristics in order to make a fair comparison, by ensuring that the difference between the two groups only stems from the implementation of the DR programme. Moreover, it is worth underlining that control group methods work well when applied to a cluster of customers, while they show poor performance in predicting the BL of an individual customer, whose consumption pattern may significantly vary over all customers belonging to the treatment group [137].

4. Social survey

End users think of electricity as a virtual commodity which is always available and ready to be used. Moreover, they do not know exactly how much they consume and pay in real-time, and mainly experience electricity indirectly through the use of electrical devices. For instance, they infer its presence when electric appliances operate and its absence when appliances stop working, e.g. during power failures. Only a fraction of end users have automation systems at their premises to track their electricity consumption in real-time either through mobile Apps or special in-home displays. However, with the introduction of DR programmes, end users should be more aware of their electricity consumption, as they need to make conscious decisions in real-time (e.g. to set the time intervals during which they would like to be flexible or to start the appliance when it is switched off by the home energy management system (HEMS)). They should also play a more active role in managing their electricity consumption, by moving the locus of control of the user's domain either to an automaton system (i.e. HEMS) or a third party (e.g. an electricity supplier or an aggregator). In this framework, analysing the propensity of end users to accept new technological solutions enabling DR cannot be done without taking into account the general factors motivating people to invest in

new home automation technologies. To this end, the end users should not be seen as entities pursuing only cost-saving objectives, but as entities driven by different motivations and needs, which do not always behave rationally. This is particularly relevant if one considers that the economic benefits of DR can be lower than those expected by the end users, thus reducing their willingness to enrol in DR programmes [138]. Beside economic benefits, the end users' behaviour can be driven by: (i) hedonic factors (focused on improving the current state of the consumer, here and now), (ii) egoistic factors (focused on the interest of the individual, thus allowing the situation to deteriorate in the short term in order to maximise profits in the future), (iii) altruistic factors (focused on how to reward others and entire communities), and (iv) environmental factors in which the individual focuses on the effects of their actions on the ecology and nature [139].

4.1. Methods

As part of the ebalance-plus project [140], funded by EU Horizon 2020 scheme, a comprehensive survey was conducted to assess energy literacy and end users' attitudes towards DR programmes in four European countries: France (FR), Denmark (DK), Italy (IT) and Spain (ES). In total, 3200 participants were selected among owners of residential buildings, 800 from each country. An online questionnaire was presented to the participants to gain insights about their acceptance of two different DLC solutions:

- **Solution 1:** external washing machine control (EWMC). A user can set the time at which the laundry shall be finished, not the laundry start time. For example, the user can load the washing machine (WM) in the morning and set the laundry end time at 5.00 p.m., when will come back from work. The washing machine will be switched on automatically at the most convenient time for the power system operation, e.g. during the off-peak demand.
- **Solution 2:** external EV charging control (EEVCC). As for the charging of the EV, the user can set the time the vehicle has to be fully charged (e.g. the next morning at 7.00 a.m.), not the starting time of the charging process. The control system will decide on the exact time to start charging the car at the most convenient time for the electricity grid.

Both solutions aim to postpone electricity consumption during the peak demand period and reduce the total energy consumption during that time; thus, reducing the cost of electricity for everyone. The questionnaire was structured as follows. First, the question "Would you be interested in using such solutions for yourself?" was posed to assess the general acceptance level of the proposed DLC solutions. Then, a list of 15 potential drivers and 18 potential barriers was presented to gain detailed insights about the main factors behind the participants' perception and acceptance of the proposed DLC solutions. Economic (EC), environmental (ENV) and technical (TECH) drivers were considered (e.g. potential cost and CO₂ savings, limited need for maintenance of the control system, etc.), as well as drivers related to the general attractiveness (ATT) of the proposed solutions (e.g. chance to impress friends and relatives with a new solution). Similarly, economic, technical and behavioural (BEHVL) barriers were taken into account, together with privacy concerns, sense of loss of control, technology distrust, and reluctance to change.

4.2. Results

Fig. 3 shows the participants' responses to the question "Would you be interested in using such solutions for yourself?". Differences in the level of acceptance of the proposed solutions can be seen among the four countries. Spain was the country with the highest acceptance rates. Above two third of participants were interested in EWMC (65%) and EEVCC (65%). A similar acceptance level was found in Italy where about 61% of participants were interested in EWMC and about 62% in EEVCC. Much less interest was shown in France (52% – EWMC; 49% – EEVCC) and Denmark (50% – EWMC; 54% – EEVCC).

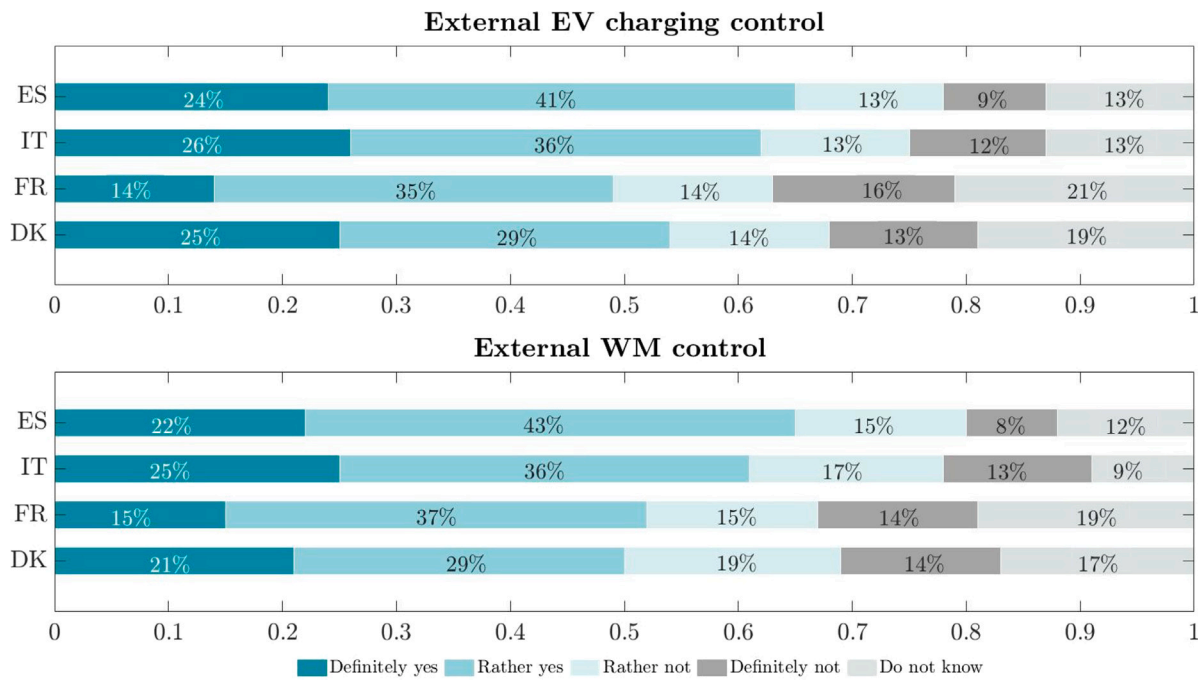

Fig. 3. Participants' willingness to adopt the proposed DLC solutions.

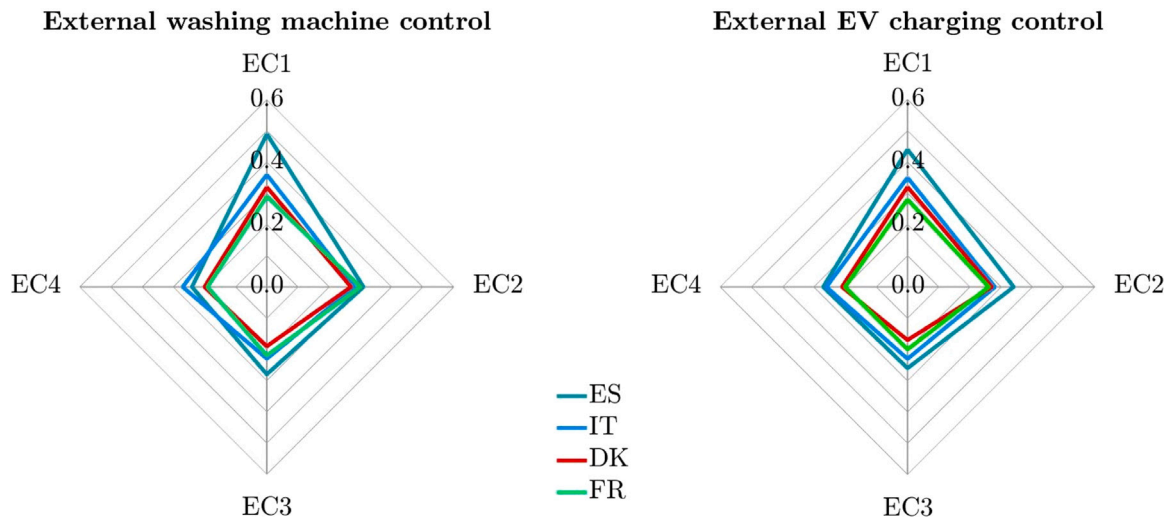

Fig. 4. Percentage of participants indicating the proposed factors as potential economic drivers.

Table 8
Economic drivers: Driver description and percentage of responding participants.

| Description | ES (%) | | IT (%) | | DK (%) | | FR (%) | |
|--|--------|----|--------|----|--------|----|--------|----|
| | WM | EV | WM | EV | WM | EV | WM | EV |
| EC1 Reduction of electricity bills | 49 | 44 | 36 | 35 | 32 | 32 | 29 | 28 |
| EC2 Free installation of the system | 31 | 34 | 28 | 28 | 27 | 27 | 30 | 26 |
| EC3 Possibility of using flex. tariffs | 28 | 26 | 23 | 23 | 19 | 17 | 22 | 20 |
| EC4 Cost-free maintenance | 24 | 27 | 27 | 26 | 20 | 21 | 19 | 20 |

4.2.1. Potential drivers

Fig. 4 shows the perception of participants about the economic factors indicated as potential economic drivers. The latter are summarised in Table 8 together with the percentage of participants who agreed on them as potential drivers (multiple choices were allowed). Electricity bill savings (EC1) and free system installations (EC2) were indicated as the main economic drivers to the presented DLC solutions in all the

analysed countries. The possibility of adopting flexible tariffs (EC3) and avoiding maintenance costs (EC4) were introduced later.

Reduction of negative impacts on the environment and the energy system come right after the driving factors with an economic nature. Fig. 5 shows how participants ranked factors related to potential environmental and system benefits (Table 9). The reduction of CO₂ emissions due to electricity consumption (ENV1) and the reduction of a negative environmental impact (ENV2) were indicated as the

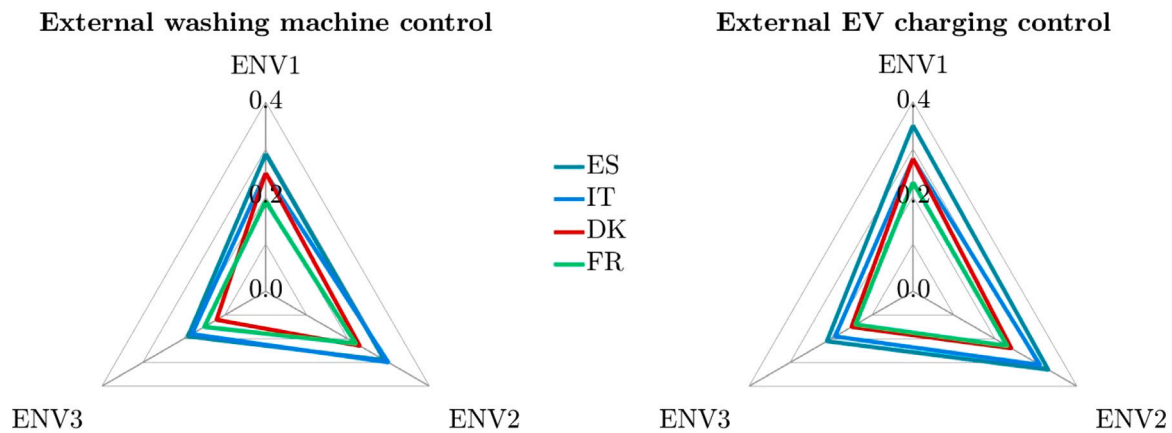

Fig. 5. Percentage of participants indicating the proposed factors as potential environmental drivers.

Table 9
Environmental and system benefits: Driver description and percentage of responding participants.

| Description | ES (%) | | IT (%) | | DK (%) | | FR (%) | |
|---|--------|----|--------|----|--------|----|--------|----|
| | WM | EV | WM | EV | WM | EV | WM | EV |
| ENV1 Reduction of CO ₂ emissions caused by electricity consumption | 29 | 35 | 25 | 28 | 25 | 28 | 19 | 23 |
| ENV2 Reduction of my negative environmental impact | 29 | 33 | 30 | 31 | 23 | 24 | 22 | 23 |
| ENV3 Safer and more stable energy grid, no outages or blackouts | 19 | 21 | 18 | 19 | 12 | 15 | 15 | 14 |

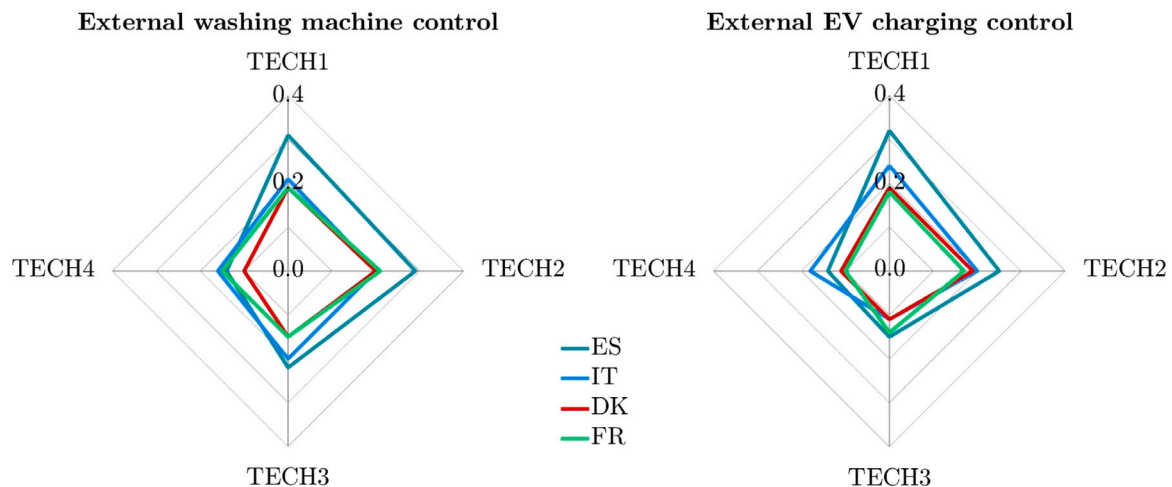

Fig. 6. Percentage of participants indicating the proposed factors as potential technical drivers.

Table 10
Comfort and technical benefits: Driver description and percentage of responding participants.

| Description | ES (%) | | IT (%) | | DK (%) | | FR (%) | |
|--|--------|----|--------|----|--------|----|--------|----|
| | WM | EV | WM | EV | WM | EV | WM | EV |
| TECH1 Ease of use/no need to engage in maintenance of the system | 31 | 32 | 21 | 24 | 19 | 19 | 19 | 18 |
| TECH2 Ease to adapt to my preferences/needs | 29 | 25 | 20 | 20 | 20 | 19 | 21 | 17 |
| TECH3 Automatic control of el. appliances | 22 | 15 | 20 | 11 | 15 | 11 | 15 | 14 |
| TECH4 Analysis of energy consumption | 14 | 14 | 16 | 18 | 10 | 11 | 15 | 10 |

main contributing factors to the proposed DLC solutions, while the positive impact on grid operations (ENV3) was indicated as a weaker motivation. On the one hand, these results may indicate that end users are mainly driven by egoistic motivations rather than by altruistic motivations. On the other hand, they can underline that end users do not consider themselves responsible for the correct and safe operation of the system and infrastructure through which electricity is delivered to them.

Fig. 6 shows the acceptance of the comfort and technical factors indicated as potential drivers. The latter are reported in Table 10. User-friendliness (TECH1) and flexibility to adapt to user needs (TECH2) were indicated as the main drivers in all the analysed countries. However, acceptance levels were significantly higher in Spain (+10% for WM control and +5% for external control of the EV) compared to Italy, Denmark and France where lower and similar answers can be observed. A moderate interest was shown for automatic control of

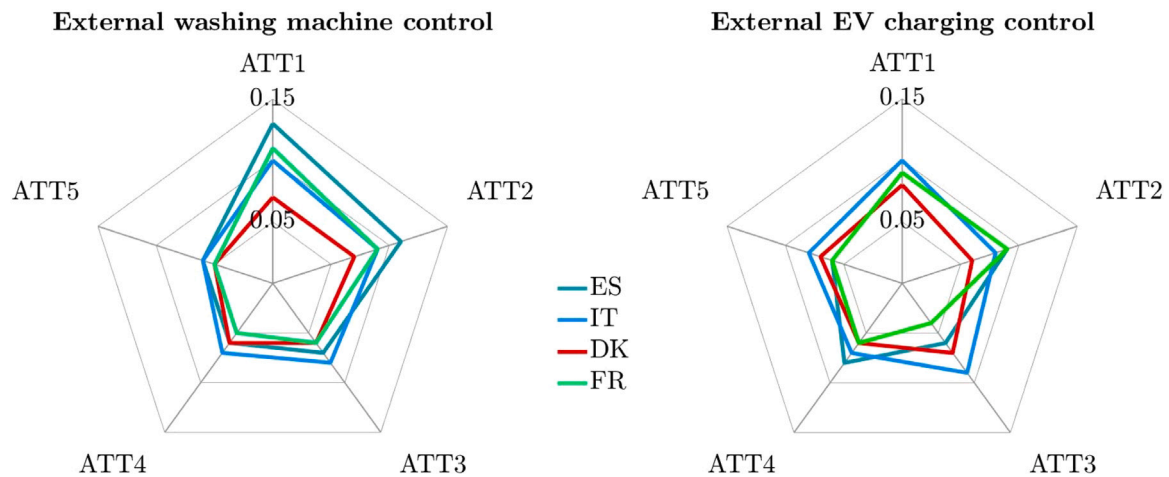

Fig. 7. Perspective of participants of factors related to the general attractiveness of the system.

Table 11
General system attractiveness: Driver description and percentage of responding participants.

| Description | ES (%) | | IT (%) | | DK (%) | | FR (%) | |
|---|--------|----|--------|----|--------|----|--------|----|
| | WM | EV | WM | EV | WM | EV | WM | EV |
| ATT1 Attractive hi-tech appliances | 13 | 9 | 10 | 10 | 7 | 8 | 11 | 9 |
| ATT2 Ability to compare my own energy consumption with others | 11 | 9 | 9 | 8 | 7 | 6 | 9 | 9 |
| ATT3 Positive feedback from family and friends | 7 | 6 | 8 | 9 | 6 | 7 | 6 | 4 |
| ATT4 My friends and family support my efforts to save energy | 6 | 8 | 7 | 7 | 6 | 6 | 5 | 6 |
| ATT5 Chance to impress my friends and relatives with a new solution | 6 | 6 | 6 | 8 | 5 | 7 | 5 | 6 |

Table 12
Economic barriers: Barrier description and percentage of responding participants.

| Description | ES (%) | | IT (%) | | DK (%) | | FR (%) | |
|--------------------------------------|--------|----|--------|----|--------|----|--------|----|
| | WM | EV | WM | EV | WM | EV | WM | EV |
| EC1 High cost of installation | 34 | 40 | 33 | 38 | 26 | 29 | 31 | 33 |
| EC2 It may require expensive repair | 26 | 24 | 23 | 26 | 30 | 26 | 20 | 20 |
| EC3 Cost benefits would be too small | 12 | 10 | 15 | 13 | 14 | 13 | 13 | 11 |
| EC4 I can afford to pay more | 6 | 6 | 4 | 4 | 5 | 6 | 9 | 8 |

electric appliances (TECH3) and for the possibility to track and analyse energy consumption (TECH4).

Lastly, Fig. 7 shows the perspective of participants towards factors related to the general attractiveness of the system (e.g. chance to impress friends and relatives with a new solution). Unlike the previous ones, these factors (Table 11) have been indicated as potential drivers by only around 10% of participants. Attractiveness of hi-tech appliances (ATT1) was indicated as the main driver, followed by the possibility to compare the energy consumption with others (ATT2). Less interest was expressed in positive feedback from family and friends (ATT3 and ATT4, respectively) and the possibility to impress others (ATT5).

4.2.2. Potential barriers

Fig. 8 demonstrates the perspective of participants of the proposed economic barriers. The latter are reported in Table 12 together with the percentages of participants that indicated them as barriers. High installation and maintenance costs (EC1 and EC2, respectively) were among the most frequently indicated barriers. There were also doubts (relatively more common in Italy and Denmark) about whether the benefits of the proposed DLC solutions would be sufficient to justify the required installation costs (EC3).

Similarly, Fig. 9 synthesises the participants' opinion on the potential technical barriers (see Table 13), e.g. maintenance and installation issues.

The main concerns were about the maintenance and installation of the devices needed to implement DLC (TECH1 and TECH2, respectively), followed by concerns about difficulties in learning how to use

them (TECH3) and the availability of high-quality technical support (TECH4). Finally, the need for assistance for the maintenance of the service was ranked at the lower position (TECH5).

Fig. 10 reveals how participants perceived the proposed behavioural barriers (see Table 14).

The most frequently indicated barrier was the lack of willingness to invest time in understanding how the proposed DLC solutions work, followed by the lack of trust in the technologies enabling DR. In France, distrust was more relevant compared to the other countries, and was the first ranked behavioural barrier. In contrast, barriers describing general resistance to change were selected least frequently. Moreover, the survey showed that only a small fraction of the participants (less or equal to 15% for each country) expressed their concern about the behavioural barriers. This demonstrates that, in general, electricity users in the surveyed countries are open to these new technologies and DR solutions.

Technologies for smart WM time management and EV charging raised privacy concerns to different degrees in the evaluated countries. Fig. 11 shows the point of view of the participants to potential barriers related to privacy concern and loss of control (see Table 15).

These two factors were mentioned relatively frequently in Spain and France, while they appeared much less frequently in Italy and were among the least frequently indicated concerns in Denmark. This shows that the same technology can elicit different responses across EU countries. Moreover, it is worth noticing that concerns about losing a sense of control over owned devices were mainly related to the control of home devices, like a WM, rather than to the EV smart charging management.

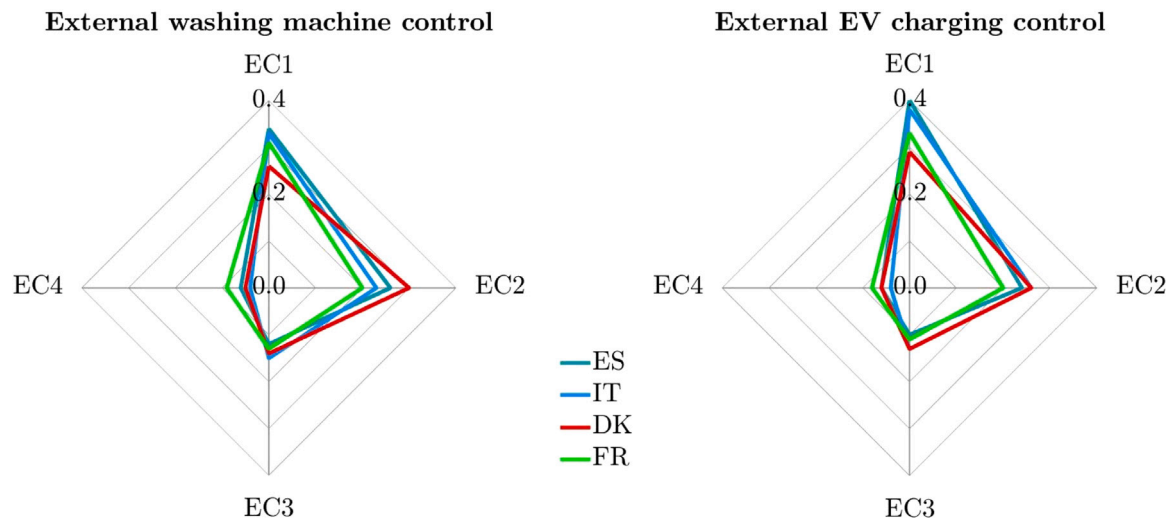

Fig. 8. Percentage of participants indicating the proposed factors as potential economic barriers.

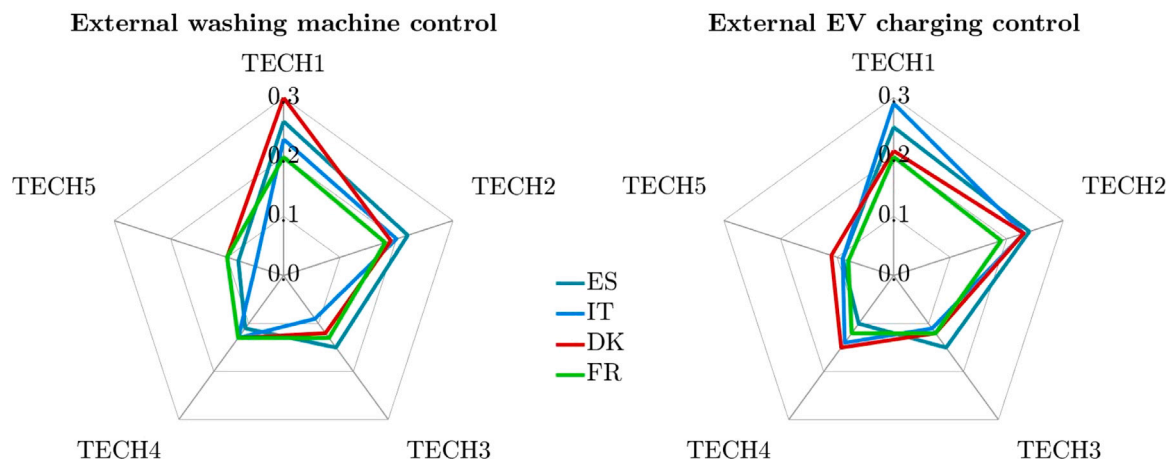

Fig. 9. Percentage of participants indicating the proposed factors as potential technical barriers.

Table 13
Technical barriers: Barrier description and percentage of responding participants.

| Description | ES (%) | | IT (%) | | DK (%) | | FR (%) | |
|-------------|--------|----|--------|----|--------|----|--------|----|
| | WM | EV | WM | EV | WM | EV | WM | EV |
| TECH1 | 26 | 25 | 23 | 29 | 30 | 21 | 20 | 20 |
| TECH2 | 22 | 24 | 20 | 23 | 19 | 23 | 18 | 19 |
| TECH3 | 15 | 15 | 9 | 11 | 12 | 12 | 13 | 12 |
| TECH4 | 11 | 10 | 13 | 14 | 13 | 15 | 13 | 12 |
| TECH5 | 8 | 9 | 5 | 9 | 10 | 11 | 10 | 8 |

Table 14
Potential behavioural (BEHVL) barriers: Barrier description and percentage of responding participants.

| Description | ES (%) | | IT (%) | | DK (%) | | FR (%) | |
|-------------|--------|----|--------|----|--------|----|--------|----|
| | WM | EV | WM | EV | WM | EV | WM | EV |
| BEHVL1 | 15 | 13 | 6 | 7 | 10 | 10 | 8 | 10 |
| BEHVL2 | 7 | 7 | 5 | 7 | 9 | 10 | 14 | 15 |
| BEHVL3 | 7 | 7 | 7 | 6 | 11 | 8 | 10 | 9 |
| BEHVL4 | 6 | 7 | 7 | 4 | 10 | 7 | 5 | 6 |
| BEHVL5 | 5 | 4 | 5 | 6 | 9 | 10 | 9 | 11 |
| BEHVL6 | 3 | 3 | 4 | 4 | 5 | 4 | 4 | 4 |

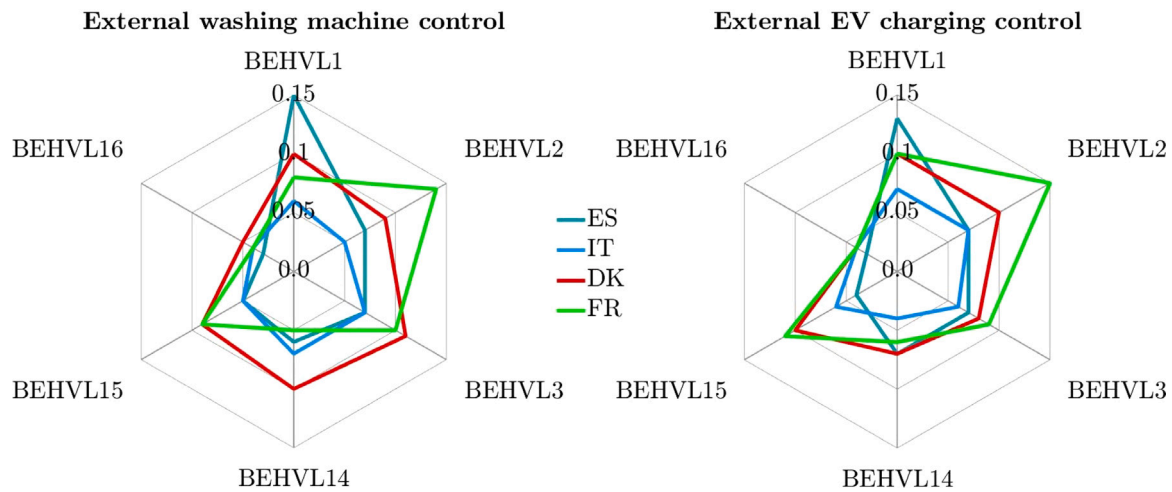

Fig. 10. Percentage of participants indicating the proposed factors as potential behavioural barriers.

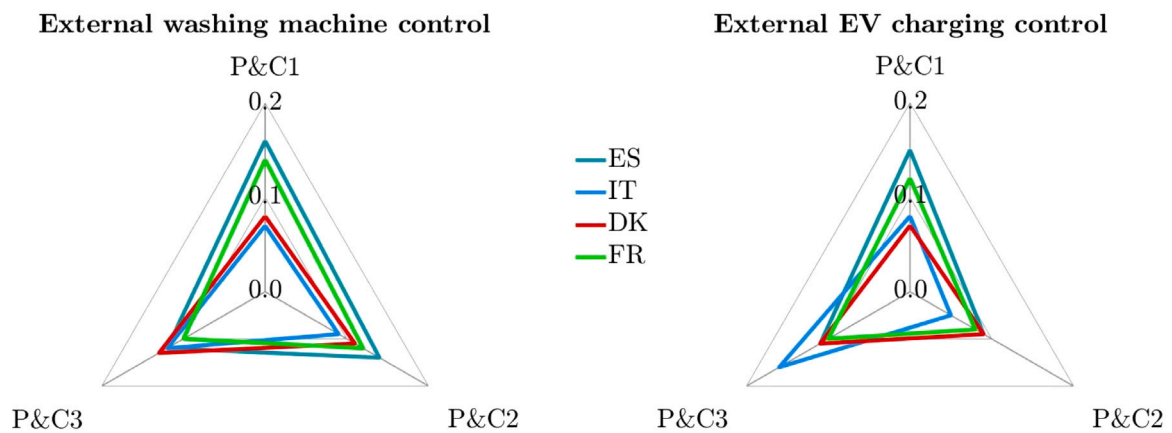

Fig. 11. Percentage of participants indicating the proposed factors as potential barriers related to privacy concern and sense of loss of control.

Table 15
Potential privacy and control (P&C) barriers: Barrier description and percentage of responding participants.

| Description | ES (%) | | IT (%) | | DK (%) | | FR (%) | |
|--|--------|----|--------|----|--------|----|--------|----|
| | WM | EV | WM | EV | WM | EV | WM | EV |
| P&C1 I am concerned about my privacy | 16 | 15 | 7 | 8 | 8 | 7 | 14 | 12 |
| P&C2 Sense of losing control | 14 | 9 | 9 | 5 | 11 | 9 | 12 | 8 |
| P&C3 Constraints in use of electricity at time that it is more convenient for me | 12 | 11 | 12 | 16 | 13 | 11 | 10 | 10 |

Lastly, it is interesting to note that the main concern was about the possibility of freely scheduling one’s own electricity consumption in Italy and Denmark, which reflects the consumer perception on electricity as a commodity.

4.3. Main findings

Results show that economic benefits, e.g. cost savings, are the main drivers of the acceptance of DLC solutions by end users, followed by environmental benefits. Technical attractiveness of the system, as well as the awareness of having advanced in-home technologies and impressing others were revealed to be minor drivers. Similarly, the factors indicated as the main barriers were of an economic nature, e.g. costs to install and maintain the system, while the end users’ willingness to change their habits and privacy concerns were indicated as minor barriers.

These findings provide an overview on the end-users’ perspective on DR and highlight potential enablers and barriers to its deployment.

However, it is worth mentioning that these findings are affected by the differences that might arise between the “intention/behaviour” declared by the participants in the survey and their actual behaviour in real life. Another aspect that must be taken into account is how the attitude of the DR participants changes over time. Indeed, it may happen that after an initial phase of great interest and active participation, the end-users’ behaviour changes until to the point where they decide to abandon the programme.

5. Discussion

The overview on the available DR programmes presented above highlighted advances in their current implementation across European countries. However, there are still regulatory, technical and social barriers ahead.

At a regulatory level, despite the efforts made by Member States to lower entry barriers to their markets (e.g. minimum bid sizes, market products, roles and responsibilities of independent aggregators), the

lack of market products designed for small flexibility resources based on their characteristic still represent a barrier. In France, where there is one of the most advanced markets for DR and DER, aggregation of DR and generation assets in the same pool is not allowed. Moreover, while primary reserve is open to DR, secondary reserve is only procured through large generators, and tertiary reserve requires a minimum bid size of 10 MW, which hampers the participation of smaller independent providers. In Finland, primary, secondary and tertiary reserve markets are fully open to all technologies, including DR. However, low procurement volumes and large minimum bid size (i.e. 5 MW) limit the DR participation in the secondary reserve market. In Italy, there is not a market-based procurement of primary reserve. Likewise, secondary reserves are currently closed to DR and DER. From 2018, however, the tertiary reserves are open to virtually aggregated units through a pilot project called “Virtually Aggregated Mixed Units” UVAM (in Italian Unitá Virtuali Abilitate Miste). As for Spain, balancing markets are currently closed to DR and storage, and aggregation is only allowed for generation. Nevertheless, large customers (contracted power above 5 MW) and renewables can participate in interruptible load programmes. Besides, a minimum bid size of 10 MW to participate in secondary and tertiary reserve markets represents a further barrier to the participation of small consumers. Measurements and pre-qualification requirements also represent a barrier to the participation of DR and DER resources in balancing markets.

With regard to the wholesale market (day-ahead (DA) and intraday (I) markets), most of the European countries are open to DR and DER, although the required minimum bid size could still be a barrier. In France, aggregators can offer DR and participate in the wholesale power market through the Block Exchange Notification of Demand Response mechanism, known as “NEBEF”, but DR and generation bids cannot be mixed into a single VPP offer. Similarly, the Finnish wholesale market is open to both DR and independent aggregators, although only through Balance Responsible Parties (BRPs) [19]. This hampers the market competition and the development of demand-side services. Moreover, no specific framework governing the relationship between the BRP and an independent aggregator is in place. However, there are no limitations on the customer’s load size and technical requirements for aggregation. Unlike France and Finland, in the Italian and Spanish wholesale markets, only generators can participate as a seller, while demand-side resources can only participate through demand bids with indication of price.

Lastly, the market-based procurement of decentralised and demand-side resources by DSOs is still at its early stage. Only some countries (i.e. France, Finland, Italy and the UK) have allowed DSOs to procure flexibility on a market basis, although under a pilot framework where clear roles and responsibilities are still missing.

Therefore, at the regulatory level, more efforts are needed to further adapt the mechanisms and requirements of the existing markets to DR and independent aggregators, and to clearly define roles and responsibilities of each market player, as well as the relationship between TSOs, DSOs and market operators.

Understanding the psychological factors behind the end users’ response is essential to develop effective demand-side management solutions and to increase their acceptance among end users. Fell et al. [141] conducted a survey to investigate the acceptability of different DR schemes, including static and dynamic tariffs and DLC, in the UK. Contrary to previous studies, authors in [142,143] found that DLC was more acceptable than price-based DR schemes, especially when the end users have the option to opt-out at any time. They also showed that 25%–30% of people are willing to use dynamic time-of-use tariffs if equipped with devices enabling an automated response to price variations. It is well-known that automation solutions at customers’ premises facilitate the control of the electric loads and the implementation of DR, however, affordable and easy-to-use technical solutions are still scarce. This is mainly due to the lack of standardised communication protocols

and the reduced interoperability levels between energy management systems and energy technologies, especially at household level [144].

It is also worth mentioning that most end users, especially in the residential sector, do not have understanding of electricity markets and they are not aware of their energy consumption and the opportunities associated with the exploitation of their energy flexibility potential [111]. Therefore, improving energy literacy is a crucial step to promote end user participation in DR programmes and foster sustainable behaviour. This can be achieved by enabling end users to continuously monitor their energy consumption (e.g. through mobile apps visualising consumption data) and gather information about potential energy-savings; exposing them to simple and easy-to-understand tariffs and DR programmes [145]. Lastly, it is worth noticing that a better understanding of markets and flexibility mechanisms could help to mitigate issues related to data privacy and security concerns, which represent additional barriers to effectively unlock the flexibility potential of the demand side. Concern for the privacy of end users data is evident in many studies focused on social acceptance of Smart Grid solutions [146,147].

6. Conclusions and recommendations

Demand-side flexibility will play a key role in reaching high levels of renewable energy generation and making the transition to a more sustainable energy system. This understanding clearly emerges from the research efforts made to develop optimised technical solutions and load management strategies to enable end users to support grid operations, while taking advantage (e.g. economic benefits) of their energy flexibility potential. In that regard, the present work presented an extensive literature review on the available DR programmes and the state of their current implementation. Special attention is paid to the features that DR programmes are expected to have in the near future to cope with the high variability and stochasticity of renewable generation on the one hand, and with the retirement of synchronous generators on the other hand. To provide a comprehensive picture of the current state of DR and analyse the practical implementation and future viability of DR programmes, the main measurement and quantification methodologies are discussed, focusing on the baseline estimation methodologies available to assess the provided flexibility and their pros and cons in terms of application with modern DR. The main findings of the review work carried out can be summarised as follows:

- Despite the efforts made at regulatory level to promote explicit DR programmes and a more active participation of the demand side in the balancing and management of the grid, the lack of market products accessible to small end users hampers the flexibility potential of the demand side, which remains untapped. Moreover, although small end users can access markets through aggregators, roles and responsibilities of traditional and new market players like demand-side aggregators and their interactions are still unclear; thus, further challenging the development of DR. In view of this, new flexibility products and marketplaces need to be further investigated. In this regard, it is worth noticing that the development of new digital platforms enabling the aggregation of flexibility from small end users and its trading into traditional and new flexibility markets can also represent a new business case for market players such as retailers and producers.
- Nowadays, implicit DR programmes are most common among small end users (especially in the residential sector). They are more easily implemented compared to explicit mechanisms since they do not require any kind of pre-qualification test or verification procedure. However, the current implicit mechanisms can be considered a first attempt to unlock the flexibility of demand-side. With higher levels of stochastic and variable generation, the needs of flexibility will become more and more dynamic,

thereby more dynamic DR mechanisms, capable of unlocking and providing demand-side flexibility on a continuous basis and close to real time, will be needed. Moreover, the limited cost savings achievable through the currently available implicit DR mechanisms, in relation to the capital costs required for equipping households with ICT and smart home energy management system, can hamper the end users' willingness to engage in implicit DR programmes. As highlighted by the social survey, economic motivations are the main driver for end users. Moreover, the dynamic component usually refers to the energy component only, which represents a small fraction of the whole electricity tariff. As a consequence, the fixed components dampen the price signal to customers, and limit the achievable cost saving potential. To mitigate these issues, research efforts focused on the design of new tariff structures are recommended. The latter should be more reflective of the actual generation and grid costs, and at the same time incentivise end users to implement load management strategies.

- As for any other product traded into a market, measurement and verification procedures are needed to verify the commitments made toward the market and set the corresponding penalties or payments. Control group methods seem to be the most suited baseline estimation method for residential end users. However, if all end users are expected to enrol in DR programmes, it will become more difficult to identify non-responsive end users in comparison to assessing the load variation of the end users participating in a DR programme (test group). Similarly, if DR programmes will continuously exploit the flexibility of end users, it will be more difficult to deploy averaging methods or to use consumption data metered just before the DR event. In the first case, there will not be non-event days, while in the second one, it will be impossible to identify what is before and what is after. In view of this, special efforts must be dedicated to the development of measurement and verification procedures consistent with the more continuous and dynamic nature of future flexibility needs.
- Finally, the propensity of the end users to accept a more active role and engagement in grid operations cannot be left out of picture to make demand-side flexibility a successful business case. End users satisfaction is critical to the viability of any DR programme. Results from the survey showed that economic motivations stand out compared to environmental or social motivations, while potential high investment and maintenance costs of technologies enabling DR appear to be the main factors damping end user willingness to participate in DR programmes. In view of this, and considering that economic benefits can be lower than expected, identifying new enablers will be essential for successful participation of end users in DR programmes.

Declaration of competing interest

The authors declare that they have no known competing financial interests or personal relationships that could have appeared to influence the work reported in this paper.

Acknowledgement

This work emanated from research conducted with the financial support of the European Commission through the H2020 project ebalance-plus (Grant Agreement 864283).

References

- [1] Krautz H, Lisk A, Posselt J, et al. Impact of renewable energies on the operation and economic situation of coal fired power stations: Actual situation of coal fired power stations in Germany. *Front. Energy* 2017;11:119–25.
- [2] IRENA. Demand-side flexibility for power sector transformation. Abu Dhabi: International Renewable Energy Agency; 2019.
- [3] O'Malley M, Kroposki B, Hannegan B, Madsen H, Andersson M, D'haeseleer W, et al. Energy systems integration. Defining and describing the value proposition. Technical Report NREL/TP-5D00-66616, International Institute of Energy Systems Integratio; June 2016. <http://dx.doi.org/10.2172/1257674>.
- [4] Fuchs G, Lunz B, Leuthold M, Sauer D. Chapter 7 - Overview of nonelectrochemical storage technologies. In: Moseley PT, Garche J, editors. *Electrochemical energy storage for renewable sources and grid balancing*. Amsterdam: Elsevier; 2015, p. 89–102.
- [5] Poullikkas A. A comparative overview of large-scale battery systems for electricity storage. *Renew Sustain Energy Rev* 2013;27:778–88.
- [6] IRENA. Innovation landscape brief: Utility-scale batteries. Abu Dhabi: International Renewable Energy Agency; 2019.
- [7] D. N. Shifting demand and supply over time and space to manage intermittent generation: The economics of electrical storage. *Energy Policy* 2018;113:711–20.
- [8] Impram S, Varbak Nese S, Oral B. Challenges of renewable energy penetration on power system flexibility: A survey. *Energy Strategy Rev* 2020;31:100539.
- [9] Frontier Economics. Evaluating flexibility as alternative to traditional network reinforcement. Prepared for the Scottish and Southern Electricity Networks, July 2020.
- [10] O'Connell N, Pinson P, Madsen H, O'Malley M. Benefits and challenges of electrical demand response: A critical review. *Renew Sustain Energy Rev* 2014;39:686–99.
- [11] Vardakas J, Zorba N, Verikoukis C. A survey on demand response programs in smart grids: Pricing methods and optimization algorithms. *IEEE Commun Surv Tutor* 2015;17(1):152–78.
- [12] European Commission. Communication from the Commission to the European Parliament, the Council, the European Economic and Social Committee, the Committee of the Regions and the European Investment Bank - Clean Energy For All Europeans.
- [13] European Commission. Directive (EU) 2018/2002 of the European Parliament and of the Council of 11 December 2018 Amending Directive 2012/27/EU on Energy Efficiency (Text with EEA relevance), OJL, December 2018; 210–230.
- [14] European Commission. Directive (EU) 2019/944 of the European Parliament and of the Council of 5 June 2019 on Common Rules for the Internal Market for Electricity and Amending Directive 2012/27/EU (Text with EEA Relevance), OJL, 14 June 2019; 125–199.
- [15] Regulation (EU) 2019/943 of the European Parliament and of the Council of 5 June 2019 on the Internal Market for Electricity (Text with EEA Relevance), OJL, 14, June 2019; 54–124.
- [16] Madsen H, Parvizi J, Halvgaard R, Sokoler L, Jørgensen J, Hansen L, et al. Control of electricity loads in future electric energy systems. In: Yan J, editor. *Handbook of clean energy systems*. 2015. <http://dx.doi.org/10.1002/9781118991978.hces033>.
- [17] Willems B, Zhou J. The clean energy package and demand response: Setting correct incentives. *Energies* 2020;13(21):5672.
- [18] Bertoldi P, Zancanella P, Boza-Kiss B. Demand response status in EU member states. 2016, EUR 27998 EN, <http://dx.doi.org/10.2790/962868>.
- [19] Smart Energy Demand Coalition (SEDC). Explicit demand response in europe mapping the markets 2017. 2018, Available at: <https://www.smartenergy.eu/wp-content/uploads/2017/04/SEDC-Explicit-Demand-Response-in-Europe-Mapping-the-Markets-2017.pdf>.
- [20] Kathirgamanathan A, Péan T, Zhang K, De Rosa M, Salom J, Kummert M, et al. Towards standardising market-independent indicators for quantifying energy flexibility in buildings. *Energy Build* 2020;220:110027.
- [21] Gao N, Ge S, Tian Y, You C. A review of decision-making strategies of profit-seeking demand response aggregators. In: 2020 IEEE sustainable power and energy conference (ISPEC). 2020, p. 2135–40.
- [22] Lu X, Li K, Xu H, Wang F, Zhou Z, Zhang Y. Fundamentals and business model for resource aggregator of demand response in electricity markets. *Energy* 2020;204:117885.
- [23] Parrish B, Heptonstall P, Gross R, Sovacool B. A systematic review of motivations, enablers and barriers for consumer engagement with residential demand response. *Energy Policy* 2020;138:111221.
- [24] Torriti J, Mohamed G, Leach M. Demand response experience in europe: Policies, programmes and implementation. *Energy* 2010;35(4):1575–83, Demand Response Resources: the US and International Experience.
- [25] Enefirst. EU H2020 funded project. Using time-of-use tariffs to engage customers and benefit the power system. 2021, Online available at: https://enefirst.eu/wp-content/uploads/1_Using-ToU-Time-of-Use-tariffs-to-engage-consumers-and-benefit-the-power-system.pdf. [accessed 13 August 2021].
- [26] Imani M, Ghadi M, Ghavidel S, Li L. Demand response modeling in micro-grid operation: a review and application for incentive-based and time-based programs. *Renew Sustain Energy Rev* 2018;94:486–99.
- [27] Abrishambaf O, Faria P, Vale Z. Participation of a smart community of consumers in demand response programs. In: 2018 Clemson University Power Systems Conference (PSC). 2018, p. 1–5.
- [28] Amber Electric. <https://www.amberelectric.com.au/>.

- [29] Energy Authority, Finland, National Report 2018 to the Agency for the Cooperation of Energy Regulators and to the European Commission. 2018.
- [30] Correia-da Silva J, Soares I, Fernández R. Impact of dynamic pricing on investment in renewables. *Energy* 2020;202:117695.
- [31] Red Eléctrica. Transmission agent and operator of the Spanish electricity system. Voluntary price for the small consumer (PVPC). Online document available at: <https://www.ree.es/en/activities/operation-of-the-electricity-system/voluntary-price-small-consumer-pvpc>.
- [32] Bhagwat P, Hadush S. Dynamic retail electricity tariffs: Choices and barriers. Florence school of regulation. 2020, Online available at: https://cadmus.eu/bitstream/handle/1814/66851/PB_2020_14_FSR.pdf?sequence=1.
- [33] IRENA. Innovation landscape brief: Time-of-use tariffs. Abu Dhabi: International Renewable Energy Agency; 2019.
- [34] Nicolson M, Fell M, Huebner G. Consumer demand for time of use electricity tariffs: A systematized review of the empirical evidence. *Renew Sustain Energy Rev* 2018;97:276–89.
- [35] Eurostat. Electricity price statistics. 2020, (Online) https://ec.europa.eu/eurostat/statistics-explained/index.php/Electricity_price_statistics#Electricity_prices_for_household_consumers [Accessed: 02/04/2021].
- [36] Swedish Energy Markets Inspectorate. Measures to increase demand side flexibility in the Swedish electricity system. Ei R2017:10. 2017, Online available at: <https://www.energi.se/om-energi/nyheter/2017/03/2017-10>. [Accessed: 09March2021].
- [37] De Zotti G, Pourmousavi S, Madsen H, Poulsen N. Ancillary services 4.0: A top-to-bottom control-based approach for solving ancillary services problems in smart grids. *IEEE Access* 2018;6:11694–706.
- [38] De Zotti G, Pourmousavi S, Morales J, Madsen H, Poulsen N. A control-based method to meet TSO and DSO ancillary services needs by flexible end-users. *IEEE Trans Power Syst* 2020;35(3):1868–80.
- [39] Bray R, Woodman B. Barriers to Independent Aggregators in Europe. Energy Policy Group Working Paper: EPG1901. 2019, University of Exeter, Online available at: https://www.centrica.com/media/4376/barriers_to_independent_aggregators_in_europe.pdf.
- [40] Helen Ltd. <https://www.helen.fi/en/company/helen-ltd>.
- [41] Fortum Oyj. <https://www.fortum.com/>.
- [42] Fortum. A thousand fortum customers' homes form a one-megawatt virtual battery. 2018, [Online]. Available at: <https://www.fortum.com/media/2018/01/thousand-fortum-customers-homes-form-one-megawatt-virtual-battery>.
- [43] Delichatsios A. Voltalis' BluePod. Another way to think energy. [Online]. Available at: <https://wattnow.org/2012/02/voltalis-bluepod-another-way-to-think-energy/>.
- [44] Centrica. The Cornwall Local Energy Market. The future of flexibility: How local energy markets can support the UK's net zero energy challenge (Project summary). [Online]. Available at: <https://www.centrica.com/innovation/cornwall-local-energy-market>.
- [45] Piclo. Piclo Flex: The independent marketplace for trading energy flexibility online. [Online]. Available at: <https://picloflex.com/>.
- [46] Jin X, Jia H. Local flexibility markets: Literature review on concepts, models and clearing methods. *Applied Energy* 2019;261:114387.
- [47] Fleiter T, Elsland R, Rehfeldt M, Steinbach J, Reiter U, Catenazzi G, et al. Profile of heating and cooling demand in 2015. D3.1 report. 2017, Heat Roadmap Europe 2050, A low-carbon heating and cooling strategy. Available at: https://heatroadmap.eu/wp-content/uploads/2018/11/HRE4_D3.1.pdf. [accessed 27 June 2019].
- [48] IRENA. Innovation landscape brief: Renewable power-to-heat. Abu Dhabi: International Renewable Energy Agency; 2019.
- [49] European Union: European Commission, Communication from the European Parliament, the Council, the European economic and social committee and the committee of the regions. A policy framework for climate and energy in the period from 2020 to 2030. 2014, COM/2014/015 final, available at: <https://eur-lex.europa.eu/legal-content/EN/ALL/?uri=CELEX%3A52014DC0015>.
- [50] Dominkovic D, Junker R, Blanco I, Lindberg K, Krajačić G, Madsen H. Demand response in district heating systems: on operational and capital savings potential. In: Abstract from 5th international conference on smart energy systems in Copenhagen, Copenhagen, Denmark. 2019.
- [51] Abdin Z, Khalilpour K. Chapter 4 - single and polystorage technologies for renewable-based hybrid energy systems. In: Khalilpour KR, editor. Polygeneration with polystorage for chemical and energy hubs. Academic Press; 2019, p. 77–131.
- [52] Majidi M, Mohammadi-Ivatloo B, Anvari-Moghaddam A. Optimal robust operation of combined heat and power systems with demand response programs. *Appl Therm Eng* 2019;149:1359–69.
- [53] Nguyen D, Ishihara T. Distributed peer-to-peer energy trading for residential fuel cell combined heat and power systems. *Int J Electr Power Energy Syst* 2021;125:106533.
- [54] Nojavan S, Majidi M, Najafi-Ghalelou A, Ghahramani M, Zare K. A cost-emission model for fuel cell/PV/battery hybrid energy system in the presence of demand response program: ϵ -constraint method and fuzzy satisfying approach. *Energy Convers Manage* 2017;138:383–92.
- [55] Majidi M, Nojavan S, Zare K. Optimal stochastic short-term thermal and electrical operation of fuel cell/photovoltaic/battery/grid hybrid energy system in the presence of demand response program. *Energy Convers Manage* 2017;144:132–42.
- [56] Dengiz T, Jochem P, Fichtner W. Demand response with heuristic control strategies for modulating heat pumps. *Appl Energy* 2019;238:1346–60.
- [57] Clauß J, Stinner S, Sartori I, Georges L. Predictive rule-based control to activate the energy flexibility of norwegian residential buildings: Case of an air-source heat pump and direct electric heating. *Appl Energy* 2019;237:500–18.
- [58] Mugnini A, Polonara F, Arteconi A. Energy flexibility in residential buildings clusters. *E3S Web Conf* 2020;197:03002.
- [59] Bee E, Prada A, Baggio P. Demand-side management of air-source heat pump and photovoltaic systems for heating applications in the Italian context. *Environmetrics* 2018;5:132.
- [60] Patteeuw D, Henze G, Helsen L. Comparison of load shifting incentives for low-energy buildings with heat pumps to attain grid flexibility benefits. *Appl Energy* 2016;167:80–92.
- [61] Finck C, Li R, Zeiler W. Optimal control of demand flexibility under real-time pricing for heating systems in buildings: A real-life demonstration. *Appl Energy* 2020;263(2020):114671.
- [62] Uytterhoeven A, Deconinck G, Arteconi A, Helsen L. Hybrid heat pump scenarios as a transition towards more flexible buildings. In: 10th international conference on system simulation in buildings, Liege, December 10-12. 2018.
- [63] De Coninck R, Helsen L. Quantification of flexibility in buildings by cost curves – Methodology and application. *Appl Energy* 2016;162:653–65.
- [64] Baeten B, Rogiers F, Helsen L. Reduction of heat pump induced peak electricity use and required generation capacity through thermal energy storage and demand response. *Appl Energy* 2017;195:184 – 195.
- [65] Péan T, Costa-Castelló R, Fuentes E, Salom J. Experimental testing of variable speed heat pump control strategies for enhancing energy flexibility in buildings. *IEEE Access* 2019;7:37071–87.
- [66] Fitzpatrick P, D'Ettore F, De Rosa M, Yadack M, Eicker U, Finn D. Influence of electricity prices on energy flexibility of integrated hybrid heat pump and thermal storage systems in a residential building. *Energy Build* 2020;223:110142.
- [67] Dong J, Shen B, Munk J, Gluesenkamp K, Laclair T, Kuruganti T. Novel PCM integration with electrical heat pump for demand response. In: 2019 IEEE power energy society general meeting (PESGM). 2019, p. 1–5.
- [68] Howlader H, Saber A, Senjyu T. Demand-side fuel-cells and controllable loads to reduce operational costs of micro-grid through optimal unit commitment. In: 2019 international conference on computer, communication, chemical, materials and electronic engineering (IC4ME2). 2019, p. 1–4.
- [69] Renaldi R, Kiprakis A, Friedrich D. An optimisation framework for thermal energy storage integration in a residential heat pump heating system. *Appl Energy* 2017;186(3):520–9.
- [70] Fischer D, Bernhardt J, Madani H, Wittwer C. Comparison of control approaches for variable speed air source heat pumps considering time variable electricity prices and PV. *Appl Energy* 2017;204:93–105.
- [71] Fischer D, Wolf T, Wapler J, Hollinger R, Madani H. Model-based flexibility assessment of a residential heat pump pool. *Energy* 2017;118:853 – 864.
- [72] Vivian J, Prataviera E, Cunsolo F, Pau M. Demand side management of a pool of air source heat pumps for space heating and domestic hot water production in a residential district. *Energy Convers Manage* 2020;225:113457.
- [73] Sperber E, Frey U, Bertsch V. Reduced-order models for assessing demand response with heat pumps – insights from the german energy system. *Energy Build* 2020;223:110144.
- [74] Alimohammadisagvand B, Jokisalo J, Sirén K. Comparison of four rule-based demand response control algorithms in an electrically and heat pump-heated residential building. *Appl Energy* 2018;209:167–79.
- [75] Knudsen M, Petersen S. Model predictive control for demand response of domestic hot water preparation in ultra-low temperature district heating systems. *Energy Build* 2017;146:55 – 64.
- [76] Alfaverh F, Denai M, Sun Y. Demand response strategy based on reinforcement learning and fuzzy reasoning for home energy management. *IEEE Access* 2020;8:39310–21.
- [77] Nagpal H, Staino A, Basu B. Automated scheduling of household appliances using predictive mixed integer programming. *Preprints* 2019;(2019020256).
- [78] Hafeez G, Wadud Z, Khan I, Khan I, Shafiq Z, Usman M, et al. Efficient energy management of IoT-enabled smart homes under price-based demand response program in smart grid. *Sensors* 2020;20(11).
- [79] Das N, Rai S, Nayak A. Scheduling operations of smart appliances using demand response. In: Patnaik S, Sen S, Mahmoud MS, editors. *Smart Village Technology: Concepts and Developments*. Cham: Springer International Publishing; 2020, p. 369–97.
- [80] Egerter A, Hopkins G, Mandel J, Verhaar H. Energy Efficiency and Electric Vehicles: How Buildings Can Pave the Way for the Global EV Revolution. Rocky Mountain Institute; 2018.
- [81] IRENA. Innovation landscape brief: Electric-vehicle smart charging. Abu Dhabi: International Renewable Energy Agency; 2019.

- [82] Izadkhast S, P. G-G, P. F. An aggregate model of plug-in electric vehicles for primary frequency control. *IEEE Trans Power Syst* 2015;30(3):1475–82.
- [83] Marinelli M, Martinenas S, Knezovic K, Andersen P. Validating a centralized approach to primary frequency control with series-produced electric vehicles. *J Energy Storage* 2020;7:63–73.
- [84] Clairand J. Participation of electric vehicle aggregators in ancillary services considering users' preferences. *Sustainability* 2020;12:1–17.
- [85] Bessa R, Matos M, Soares F, Lopes J. Optimized bidding of an EV aggregation agent in the electricity market. *IEEE Trans Smart Grid* 2016;3(1):443–52.
- [86] Gunkel P, Bergaentzlc C, Jensen I, Scheller F. From passive to active: Flexibility from electric vehicles in the context of transmission system development. *Appl Energy* 2020;277:115526.
- [87] Shafie-khah M, Heydarian-Forushani E, Osório G, Gil F, Aghaei J, Barani M, et al. Optimal behavior of electric vehicle parking lots as demand response aggregation agents. *IEEE Trans Smart Grid* 2016;7(6):2654–65.
- [88] Jampeethong P, Khomfoi S. Coordinated control of electric vehicles and renewable energy sources for frequency regulation in microgrids. *IEEE Access* 2020;8:141967–76.
- [89] Cao C, Wu Z, Chen B. Electric vehicle–grid integration with voltage regulation in radial distribution networks. *Energies* 2020;13(7):1802.
- [90] Abul'Wafa A, El'Garably A, Mohamed W. Electric vehicle-to-home concept including home energy management. *Int J Eng Inf Syst* 2017;1(6):20–8.
- [91] H.S. D, M.M. R, Li S, C.W. T. Electric vehicles standards, charging infrastructure, and impact on grid integration: A technological review. *Renew Sustain Energy Rev* 2020;120:109618.
- [92] CSIRO, Energy Networks Australia (ENA). Electricity network transformation roadmap: Final report, energy networks Australia, canberra. 2017.
- [93] Colthorpe A. Virtual Power Plant demonstration in Australia shows financial and network value of home batteries. 2020, Online available at: <https://www.energy-storage.news/blogs/virtual-power-plant-demonstration-in-australia-shows-financial-and-network> [Accessed: 31/03/2021].
- [94] IEA. Energy storage. 2020, IEA, Paris. (Online) <https://www.iea.org/reports/energy-storage> [Accessed: 01/04/2021].
- [95] Sonnen GmbH. Store wind energy instead of wasting it - sonnen's virtual power plant helps save energy that would be lost otherwise. 2020, (Online) Accessed:31/03/2021.
- [96] Next Kraftwerke. Sonnen and next kraftwerke co-operate to supply primary control reserve. 2020, (Online) <https://www.next-kraftwerke.com/news/sonnen-next-kraftwerke-co-operate-fcr-home-batteries>. [Accessed: 31/03/2021].
- [97] IRENA. Innovation landscape brief: Net billing schemes. Abu Dhabi: International Renewable Energy Agency; 2019.
- [98] IRENA. Innovation landscape brief: Behind-the-meter batteries. Abu Dhabi: International Renewable Energy Agency; 2019.
- [99] EUPD Research. The German market for residential energy storage systems grows by one third in the first half of 2019: Bavarian manufacturer sonnen was able to expand its leading position. 2019, (Online) <https://www.eupd-energy.de/wp-content/uploads/Pressemittelungen/The-German-market-for-residential-energy-storage-systems-grows-by-one-third-in-the-first-half-of-2019.pdf> [Accessed: 01/04/2021].
- [100] Mejía-Giraldo D, Velásquez-Gomez G, Muñoz Galeano N, Cano-Quintero J, Lemos-Cano S. A BESS sizing strategy for primary frequency regulation support of solar photovoltaic plants. *Energies* 2019;12(2):317.
- [101] Kumar A, Meena N, Singh A, Deng Y, He X, Bansal R, Kumar P. Strategic integration of battery energy storage systems with the provision of distributed ancillary services in active distribution systems. *Appl Energy* 2019;253:113503.
- [102] Engels J, Claessens B, Deconinck G. Techno-economic analysis and optimal control of battery storage for frequency control services, applied to the German market. *Appl Energy* 2019;242:1036 – 1049.
- [103] Almasalma H, Deconinck G. Simultaneous provision of voltage and frequency control by PV-battery systems. *IEEE Access* 2020;8:152820–36, <http://dx.doi.org/10.1109/ACCESS.2020.3018086>.
- [104] Beltran H, Harrison S, Egea-Álvarez A, Xu L. Techno-economic assessment of energy storage technologies for inertia response and frequency support from wind farms. *Energies* 2020;13:3421.
- [105] Schiapparelli G, Massucco S, Namor E, Sossan F, Cherkaoui R, Paolone M. Quantification of primary frequency control provision from battery energy storage systems connected to active distribution networks. In: 2018 Power Systems Computation Conference (PSCC). 2018, p. 1–7.
- [106] Engels J, Claessens B, Deconinck G. Optimal combination of frequency control and peak shaving with battery storage systems. *IEEE Trans Smart Grid* 2020;11(4):3270–9.
- [107] Zhu D, Zhang Y. Optimal coordinated control of multiple battery energy storage systems for primary frequency regulation. *IEEE Trans Power Syst* 2019;34(1):555–65.
- [108] Ramírez M, Castellanos R, Calderón G, Malik O. Placement and sizing of battery energy storage for primary frequency control in an isolated section of the Mexican power system. *Electr Power Syst Res* 2018;160:142–50.
- [109] El-Bidairi K, Nguyen H, Mahmoud T, Jayasinghe S, Guerrero J. Optimal sizing of Battery Energy Storage Systems for dynamic frequency control in an islanded microgrid: A case study of Flinders Island, Australia. *Energy* 2020;195:117059.
- [110] Englberger S, A. J, H. H. Unlocking the potential of battery storage with the dynamic stacking of multiple applications. *Cell Rep Phys Sci* 2020;1(11):100238.
- [111] Pallonetto F, De Rosa M, D'Ettorre F, Finn D. On the assessment and control optimisation of demand response programs in residential buildings. *Renew Sustain Energy Rev* 2020;127:109861.
- [112] Lopes R, Chambel A, Neves J, Aelenei D, Martins J. A literature review of methodologies used to assess the energy flexibility of buildings. *Energy Procedia* 2016;91:1053–8, Proceedings of the 4th International Conference on Solar Heating and Cooling for Buildings and Industry (SHC 2015). URL <https://www.sciencedirect.com/science/article/pii/S1876610216303745>.
- [113] Clauß J, Finck C, Vogler-Finck P, Beagon P. Control strategies for building energy systems to unlock demand side flexibility—A review. In: IBPSA Building Simulation 2017, San Francisco, 7-9 August 2017. IBPSA; 2017.
- [114] Sun M, Djapic P, Aunedi M, Pudjianto D, Strbac G. Benefits of smart control of hybrid heat pumps: An analysis of field trial data. *Appl Energy* 2019;247:525–36.
- [115] D'hulst R, Labeeuw W, Beusen B, Claessens S, Deconinck K. Demand response flexibility and flexibility potential of residential smart appliances: Experiences from large pilot test in Belgium. *Appl Energy* 2015;155:79–90.
- [116] Six D, Desmedt J, Vanhoudt D, Van Bael J. Exploring the flexibility potential of residential heat pumps combined with thermal energy storage for smart grids. In: 21st international conference on electricity distribution. 2011, p. 0442–0442.
- [117] Arteconi A, Polonara F. Assessing the demand side management potential and the energy flexibility of heat pumps in buildings. *Energies* 2018;11(7):1846.
- [118] D'Ettorre F, Brennenstuhl M, Kathirgamanathan A, De Rosa M, Yadack M, Eicker U, et al. A set of comprehensive indicators to assess energy flexibility: a case study for residential buildings. In: E3S Web of Conferences. E3S Web of Conferences, 111, 2019, p. 04044.
- [119] Junker R, Azar A, Lopes R, Lindberg K, Reynders G, Relan R, Madsen H. Characterizing the energy flexibility of buildings and districts. *Appl Energy* 2018;225:175–82.
- [120] Dahl Knudsen M, Petersen S. Demand response potential of model predictive control of space heating based on price and carbon dioxide intensity signals. *Energy Build* 2016;125:196–204.
- [121] Sharifi R, Fathi S, Vahidinasab V. Customer baseline load models for residential sector in a smart-grid environment. *Energy Rep* 2016;2:74–81.
- [122] Le Ray G, Larsen E, Pinson P. Evaluating price-based demand response in practice – with application to the EcoGrid EU experiment. *IEEE Trans Smart Grid* 2016;9:2304–13.
- [123] Ziras C, Heinrich C, Pertl M, Bindner H. Experimental flexibility identification of aggregated residential thermal loads using behind-the-meter data. *Appl Energy* 2019;242:1407–21.
- [124] Müller F, Jansen B. Large-scale demonstration of precise demand response provided by residential heat pumps. *Appl Energy* 2019;239:836–45.
- [125] Corradi O, Ochsenfeld H, Madsen H, Pinson P. Controlling electricity consumption by forecasting its response to varying prices. *IEEE Trans Power Syst* 2013;28(1):421–9.
- [126] EnerNOC. The demand response baseline and white paper. 2011.
- [127] Rossetto N. Measuring the intangible: an overview of the methodologies for calculating customer baseline load in PJM. *FSR Policy Rep.* 2018/05 2018. <https://fsr.eui.eu/publications/?handle=1814/54744>.
- [128] Goldberg M, Agnew G. Protocol development for demand response calculations: Findings and recommendations. In: Prepared for the California energy commission. KEMA, Inc., no. CEC 400–02-017F; 2003.
- [129] KEMA. PJM empirical analysis of demand response baseline methods. Clark Lake, MI, USA, White Paper: KEMA, Inc.; 2011, [Online]. Available: <http://pjm.com/markets-and-operations/demand-response/~media/markets-ops/dsr/pjm-analysis-of-dr-baseline-methods-full-report.aspx>.
- [130] Coughlin K, Piette M, Goldman C, Kiliccote S. Statistical analysis of baseline load models for non-residential buildings. *Energy Build* 2009;41(4):374–81.
- [131] Wijaya T, Vasirani M, Aberer K. When bias matters: An economic assessment of demand response baselines for residential customers. *IEEE Trans Smart Grid* 2014;5(4). <http://dx.doi.org/10.1109/TSG.2014.2309053>.
- [132] Li K, Wang B, Wang Z, Wang F, Mi Z, Zhen Z. A baseline load estimation approach for residential customer based on load pattern clustering. *Energy Procedia* 2017;142:2042–9.
- [133] Bode J, Sullivan M, Berghman D, Eto J. Incorporating residential AC load control into ancillary service markets: Measurement and settlement. *Energy Policy* 2013;56:175–85.
- [134] Newsham G, Birt B, Rowlands I. A comparison of four methods to evaluate the effect of a utility residential air-conditioner load control program on peak electricity use. *Energy Policy* 2011;39(10):6376–89.
- [135] Jazaeri J, Alpcan T, Gordon R, Brandao M, Hoban T, Seeling C. Baseline methodologies for small scale residential demand response. *IEEE Innov Smart Grid Technol* 2016. Asia (ISGT-Asia) Melbourne, Australia, Nov 28 - Dec 1, 2016.
- [136] Hatton L, Charpentier P, Matzner-Løber E. Statistical estimation of the residential baseline. *IEEE Trans Power Syst* 2016;31(3). <http://dx.doi.org/10.1109/TPWRS.2015.2453889>.

- [137] Lee E, Lee K, Lee H, Kim E, Rhee W. Defining virtual control group to improve customer baseline load calculation of residential demand response. *Appl Energy* 2019;250:946–58.
- [138] Kowalski J, Matusiak B. End users' motivations as a key for the adoption of the home energy management system. *Int J Manag Econ* 2019;55:13–24.
- [139] Steg L. Values, norms, and intrinsic motivation to act proenvironmentally. *Annu Rev Environ Resour* 2016;41:277–92.
- [140] E.U. H2020 project ebalance-plus (Grant Agreement 864283), <https://www.ebalanceplus.eu/>.
- [141] Fell M, Shipworth D, Huebner G, Elwell C. Public acceptability of domestic demand-side response in Great Britain: The role of automation and direct load control. *Energy Res Soc Sci* 2015;9:72–84.
- [142] Darby S, Pisica I. Focus on electricity tariffs: experience and exploration of different charging schemes. in: *Eceee Summer Study Proceedings ECEESummer Study 2013*;2321–31.
- [143] Parkhill K, Demski C, Butler C, Spence A, Pidgeon N. Transforming the UK Energy System: Public Values, Attitudes and Acceptability—Synthesis Report, orgname=UKERC, city=London. 2013.
- [144] Weck M, van Hooff J, van Sark W. Review of barriers to the introduction of residential demand response: a case study in the Netherlands. *Int J Energy Res* 2017;41:790–816.
- [145] Darby S, McKenna E. Social implications of residential demand response in cool temperate climates. *Energy Policy* 2012;49:759–69.
- [146] Muench S, Thuss S, Guenther E. What hampers energy system transformations? The case of smart grids. *Energy Policy* 2014;73:80–92.
- [147] Raimi K, Carrico A. Understanding and beliefs about smart energy technology. *Energy Res Soc Sci* 2016;12:68–74.